

OWNER'S MANUAL

# TORRES



## Recommended Fluids and Lubricants

Descriptions		Capacity	Specifications	
Engine Oil	G15DTF	≈ 4.5 ℓ	Quality class: KG Mobility genuine engine oil or Approved by ACEA C2 SAE 0W/30	
Engine Coolant	G15DTF	≈ 7.0 ℓ	KG Mobility genuine coolant Anti-Freeze: SYC-1025 Anti-Freeze:Water = 50:50 ORGANIC ACID TYPE, COLOR:BLUE	
Automatic Transaxle Fluid	G15DTF	≈ 6.2 ℓ	KG Mobility genuine oil (AW-1)	
Manual Transaxle Fluid	G15DTF	≈ 1.95 ℓ	KG Mobility genuine oil (SK ZIC SYN MTF 70W)	
Transfer Case (PTU) Fluid	G15DTF	A/T	≈ 0.6 ℓ	KG Mobility genuine oil (SAE 80W/90, API GL-5)
Rear Axle Oil	AWD	≈ 0.6 ℓ	KG Mobility genuine oil (SAE 80W/90, API GL-5)	
Brake / Clutch Fluid		As required	KG Mobility genuine oil (DOT4)	



### Warning

- Use only KG Mobility recommended fluids and lubricants.
- Do not mix any different types or brands of oils or fluids. This may cause damages.
- Keep the specified levels when adding or replacing the fluids.

### Notice

- The antifreeze mixture ratio at the time of vehicle delivery is 45%.

## Foreword

This section provides useful information to know in advance for reading the owner's manual.

Information regarding the marks used in the owner's manual, change of car design, and periodic check is provided.

**Thank you for purchasing the TORRES.**

TORRES you selected is a vehicle with superior safety and quality and the latest technologies. KG Mobility Corporation has been carrying out and initiating R&D activities continuously in the industry.

Please read this owner's manual carefully before driving the TORRES. You can drive safely and economically by utilizing the technical advantages applied to the vehicle.

We will dedicate ourselves to ensure that you can always drive the TORRES pleasantly and safely.



## Purpose and Application Conditions of the Owner's manual

This owner's manual has been prepared to provide information for the specifications and functions of the vehicle, and important safety information including cautions and warnings for safe driving and correct vehicle maintenance.

- All descriptions, pictures, and drawings included in this owner's manual are based on the time of the document's preparation. If there is a change in the specifications (options) and functions according to a change of design, some content may be different from the actual vehicle.
- This owner's manual has been prepared based on all specifications (options) of the vehicle. Please understand that an explanation of a specification (options) which is not provided for your vehicle may be provided.

As some options or option packages may be added or deleted randomly depending on the vehicle point of sale and design changes, make sure that the options you applied when signing the contract are fitted to your vehicle prior to reading this owner's manual.

Please read this owner's manual carefully before driving the vehicle, to ensure safe driving and the best vehicle performance.

## Open Source Software Notice Information

To obtain the source code under GPL, LGPL, MPL, and other open source licenses, that is contained in this product, please visit <http://opensource.lge.com>.

In addition to the source code, all referred license terms, warranty disclaimers and copyright notices are available for download.

LG Electronics will also provide open source code to you on CD-ROM for a charge covering the cost of performing such distribution (such as the cost of media, shipping, and handling) upon email request to [opensource@lge.com](mailto:opensource@lge.com).

This offer is valid for a period of three years after our last shipment of this product. This offer is valid to anyone in receipt of this information.

## Marks Used in this Owner's manual

---



It indicates a dangerous situation (DANGER) that may likely to lead to death or serious injury.

It should be observed for the safety of the driver and other passengers.

---



It indicates a dangerous situation (WARNING) that may lead to death or serious injury.

It should be observed for the safety of the driver and other passengers.

---

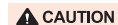

It indicates a dangerous situation (CAUTION) that may lead to moderate or minor injury, or a situation that may lead to damage to the vehicle.

It should be observed for the safety of the driver and other passengers and the prevention of property damage.

---



It is used for explaining additional information or procedures related to the vehicle and driving.

---



It is used to indicate the location of relevant information useful for using the product.

---

### **Change of Specifications (options) and Functions According to a Change of Design**

The design is subject to change without prior notice for improving the safety and performance of the vehicle. Therefore, a vehicle specification (options) may be added or deleted, or a function may change.

The content explained in this owner's manual may be different from your vehicle.

### **Do Not Use Vehicle Components for Other Purposes**

Do not use vehicle components for other purposes. KG Mobility Corporation is not liable for any consequent damages.

### **Importance of a Periodic Check**

Have your vehicle checked and maintained at a prescribed period in order to maintain the performance of the vehicle and to prevent the reduction of its life.

### **Information for Using KG Mobility Authorized Service Center**

KG Mobility Corporation is not liable for any problem that occurred due to maintenance carried out by a service center other than KG Mobility Authorized Service Center.

## Table of Contents

The table of contents is provided in three types to allow you to find necessary information in a convenient method easily and fast.

- Introduction to chapters - You can identify the content of each chapter at a glance.
- Detailed table of contents - You can find desired information using a name through the detailed title for the relevant chapter.
- Table of pictures - You can find desired information using a picture easily even if you do not know the title of the desired information.

# Introduction to Chapters

Identify the contents of each chapter at a glance.

## Foreword

- You can check information regarding the marks used in the instruction manual, change of car design, and periodic check.

## 1. Vehicle Information and Safety Precautions

- You can check helpful information for driving and managing the vehicle safely and conveniently.
- Information regarding the vehicle identification, specifications, check points before driving the vehicle, safety precautions while driving, and vehicle maintenance methods is provided.

## 2. Safety Units

- You can check information regarding devices that allow you to drive the vehicle safely and how to use such devices.
- An explanation is provided for seat belts, a baby car seat, airbags, anti-theft, and warning system.

## 3. Convenient Equipment

- You can check information regarding devices that allow you to drive the vehicle conveniently and usefully and how to use such devices.
- An explanation is provided for doors, seats, windows, as well as various convenient equipment including the tailgate, various lights and lamps, mirrors, heater and A/C, AV navigation, storage and cargo box.

## 4. Starting and driving

- You can check information regarding the basic auxiliaries for safe driving, auxiliary equipment that helps you to drive comfortably, and how to use such equipment.
- An explanation is provided for the START/STOP switch and smart key as well as the driving system including the instrument cluster, gear shift lever, 4WD, cruise control, auxiliary driving system such as the brake and autonomous emergency braking system, rear and side warning lane departure warning system, and parking assistance system.

## 5. Emergency Measures in the Event of Emergency

- You can check useful information and emergency measures for various emergency situations you can face while driving.
- Information regarding the warning triangle and OVM tools, and a correct measure in case of a dead battery, engine overheating, flat tire, and towing a vehicle is provided. An explanation is also provided for how to respond to a fire, heavy snow, vehicle trouble, and an accident safely.

## 6. Periodic Checking and Maintenance

- You can check the necessary periodic check and maintenance methods in detail for safe and pleasant vehicle driving.

## Index

- You can find important functions or terms from the content of this instruction manual in alphabetical order conveniently.



# Detailed Table of Contents

Find the desired information using a name through detailed titles.

## 1. Vehicle Information and Safety Precautions

Information regarding the installation of ADR and provision of information ..... 1-2

Precautions for potentially hazardous seat belt related goods..... 1-3

Precautions for the reduction of non-crash incidents ..... 1-4

Cautions for the protection of the environment..... 1-5

Certification ..... 1-6

Vehicle identification..... 1-9

Certification label ..... 1-9

Vehicle Identification Number (VIN)..... 1-9

Vin Label\*..... 1-9

Engine number ..... 1-9

Dimensions..... 1-10

Specifications ..... 1-11

Precautions for the modification of the vehicle and structural alteration ..... 1-14

Checking before driving ..... 1-16

Daily inspection ..... 1-16

Checking engine room ..... 1-16

Checking engine coolant ..... 1-16

Checking engine oil ..... 1-16

Checking brake fluid (clutch fluid) .. 1-17

Checking washer fluid ..... 1-17

Checking belts..... 1-17

Checking tires ..... 1-17

Checking the instrument cluster ..... 1-18

Checking the parking brake ..... 1-18

Checking the pedals ..... 1-19

Cleaning up near the driver's seat..... 1-19

Advisable driving position..... 1-19

Adjusting the seat, headrest, steering wheel, and mirrors..... 1-19

Wearing the seat belt correctly ..... 1-20

Safety and cautions for driving..... 1-21

No drugged, drunk, distracted and drowsy (4D) driving..... 1-21

Cautions for air bag ..... 1-21

Precautions for infants, children, old people, or pregnant women ..... 1-22

An infant or a small child must be seated in the rear seat with protective gear ..... 1-22

No sleeping in a sealed vehicle ..... 1-22

Do not drive with the doors or tailgate open..... 1-23

Do not hold a part of your body out of the window or sunroof ..... 1-23

Be careful not to have a part of your body caught when using the power window ..... 1-23

Check for any vehicles or persons passing by when getting out ..... 1-24

Safe parking and stopping..... 1-24

Warming up the engine correctly ..... 1-24

Do not stop the engine while driving..... 1-25

No sudden starting, acceleration or braking..... 1-25

Driving on unpaved and mountain roads .....	1-25
In high mountain area .....	1-25
Driving on a snowy or icy road .....	1-25
Driving on a sandy or muddy road .....	1-25
Driving on a hillside road and downhill road .....	1-26
Driving on a road with a pool of water or a river .....	1-26
Do not use a cellular phone or watch DMB while driving .....	1-26
Driving on the expressway .....	1-27
Crossing an intersection or railroad crossing .....	1-27
No sudden maneuvering of the steering wheel .....	1-27
Do not warm up the engine or check the vehicle in a sealed space .....	1-27
Use of the engine brake .....	1-27
Cautions for attaching accessories .....	1-28
Special cautions when checking the coolant .....	1-28
Do not load hazardous materials .....	1-28
Cautions for vehicle ventilation .....	1-28

System protection function (delayed accelerator pedal response) .....	1-28
Placement of extinguisher .....	1-28

## **Vehicle management ..... 1-29**

KG Mobility Authorized Service Center and maintenance partners .....	1-29
Cautions for the depletion of battery when connecting uninterruptible power supply to the black box system .....	1-29
Long-term parking mode .....	1-29
Breaking in a new vehicle correctly .....	1-29
Using genuine parts .....	1-29
Vehicle washing .....	1-30
Washing the bumper .....	1-31
Washing wheels .....	1-31
Cautions for polishing the vehicle .....	1-31
Cleaning and maintaining glass .....	1-32
Cautions for window tinting .....	1-32
Care and cleaning of the interior .....	1-32
Seat Belt Care .....	1-33
Cautions for using the vehicle key .....	1-33
Corrosion protection .....	1-33
Sheet Metal Damage .....	1-33

Foreign Material Deposits .....	1-33
Finish Damage .....	1-34
Underbody Maintenance .....	1-34
System safety mode .....	1-35
Vehicle Fueling from Drums or Storage Containers .....	1-35
Fuel recommendation .....	1-35
Gasoline Engine .....	1-35
Fuel Recommendation .....	1-35
Do not Use Methanol .....	1-36
Engine check indicator .....	1-36
Other maintenance .....	1-36

## **2. Safety Units**

### **Seat belt ..... 2-2**

Seat belt warning .....	2-2
Front seat (driver / passenger) belt reminder .....	2-3
Front seat (passenger) belt reminder .....	2-3
Rear seat (left / center / right) belt reminder* .....	2-3
Fastening the seat belt .....	2-4
Unfastening the seat belt .....	2-5

Managing the seat belt .....	2-5	Table of Vehicle Handbook Information on ISOFIX Child Restraint Systems Installation Suitability for Various ISOFIX Positions .....	2-13	Warning For Child Restraint .....	2-19
Adjusting the height of the front seat belt .....	2-5	Table of Vehicle Handbook Information for Installation in Various Seating Positions on i-Size Child Restraint Systems .....	2-14	<b>Air bag*</b> .....	<b>2-20</b>
Rear seat belt storage .....	2-6	List of suitable universal Child Restraint Systems (CRS) .....	2-14	Air bag warning label .....	2-20
Rear seat buckle storage .....	2-6	List of suitable ISOFIX Child Restraint Systems (CRS) .....	2-14	Air bag warning lamp .....	2-20
Rear center seat belt storage .....	2-6	List of suitable i-Size Child Restraint Systems (CRS) .....	2-14	Air bag crash sensor and air bag control module .....	2-21
Rear center seat belt release .....	2-6	Installation of crs secured by the seatbelt .....	2-15	Configuration of air bag .....	2-21
How to fasten the seat belts (2-point) in rear center seat .....	2-7	Front-facing Child Seat .....	2-15	Passenger Air Bag ON/OFF Switch* .....	2-21
How to fasten the seat belt (3-point) in rear center seat .....	2-7	Rear-facing Child Seat .....	2-15	Driver air bag .....	2-22
Seat belt pretensioner and load limiter .....	2-8	<b>Securing a child restraint system with “ISOFIX/i-Size” system and “Tether Anchorage” system* .....</b>	<b>2-17</b>	Driver knee air bag .....	2-22
Pretensioner .....	2-8	Locations of ISOFIX/i-Size Lower Anchors and Top Tether .....	2-17	Front passenger air bag .....	2-22
Load limiter .....	2-9	How to use ISOFIX/i-Size Lower Anchor .....	2-17	Front seat side air bag .....	2-23
Fastening the seat belt by a pregnant woman .....	2-9	How to use Top Tether .....	2-18	Far side air bag .....	2-23
Warnings for the seat belt .....	2-9			Curtain air bag .....	2-23
<b>Child restraint for an infant or a small child .....</b>	<b>2-11</b>			Cases where the air bag does not inflate .....	2-24
Infant and child safety .....	2-12			In the event of a slight collision .....	2-24
Child Seat .....	2-12			In the event of a rear end collision .....	2-24
Table of Vehicle Handbook Information on Child Restraint Systems Installation Suitability for Various Seating Positions .....	2-12			In the event of a side collision .....	2-25

In case the vehicle moves beneath another vehicle .....	2-26
In the event of a rollover accident .....	2-26
Secondary injury due to air bag deployment .....	2-26
Other cases .....	2-27
Warnings for the air bag .....	2-27

**Tire pressure monitoring system (TPMS)\* .....** **2-29**

Checking the tire pressure .....	2-29
If the tire pressure or the TPMS is abnormal .....	2-30
Display of the TPMS status on the instrument cluster .....	2-31
When low tire pressure is detected .....	2-33
When you have rotated the tires .....	2-33
Cautions for the TPMS .....	2-34

**Anti-theft and warning system .....** **2-35**

Immobilizer system* .....	2-35
Immobilizer/smart key warning light .....	2-35
If the engine does not start .....	2-36
When the transponder is damaged .....	2-36

When you lose the key .....	2-36
Theft deterrent system .....	2-37
Entering the theft monitoring mode .....	2-37
Activating the theft alarm .....	2-38
Holding the theft alarm .....	2-38
Canceling the theft monitoring mode .....	2-38

**3. Convenient Equipment**

**Door .....** **3-2**

How To Lock/Unlock & Open Door .....	3-2
Door Opening Lever .....	3-2
How To Check If Door Locked/Unlocked .....	3-2
Door Lock/Unlock button .....	3-2
Auto door lock function at the time of driving .....	3-3
Auto door unlock function at the time of collision .....	3-3
How To Lock Doors In Emergency .....	3-4
To lock doors with mechanical key (excluding driver door) .....	3-4
Child safety door lock .....	3-5

Locking/unlocking the door lock .....

**3-5**

**Seat .....** **3-6**

Seat & adjustment switch / button / lever .....	3-6
Front seat .....	3-7
Adjusting the headrest .....	3-7
Adjusting the front and rear angles .....	3-7
Adjusting the height .....	3-7
Separation/installation .....	3-7
Adjusting the power seat* .....	3-8
Front and rear position adjustment (driver seat/front passenger seat) .....	3-8
Adjusting the height (driver seat/front passenger seat) .....	3-8
Adjusting the cushion angle (driver seat/front passenger seat) .....	3-9
Adjusting the backrest angle (driver seat/front passenger seat) .....	3-9
Adjusting the lumbar support (driver seat) .....	3-9
Adjusting the seat manually .....	3-10
Front and rear position adjustment (driver seat/front passenger seat) .....	3-10
Adjusting the backrest angle (driver seat/front passenger seat) .....	3-11
Adjusting the height (driver seat) .....	3-11



**Fuel inlet ..... 3-34**

Opening the fuel inlet .....3-34

Closing the fuel inlet .....3-35

**Lights and lamps ..... 3-36**

Outdoor lights/lamps .....3-36

Light switch .....3-37

Turning on the head light ..... 3-37

Turning on the tail light ..... 3-37

Activating the auto light function\* · 3-37

Turning off all lights ..... 3-37

Turning on the front fog light\* ..... 3-37

Turning on the rear fog light\* ..... 3-37

Turning off the fog light\* ..... 3-37

Turning on/off the left/right turn

signal ..... 3-37

Turning on/off the high beam ..... 3-38

Turning on the high beam and low beam

at the same time (passing light) ··· 3-38

Hazard warning lamp .....3-38

Adjusting the angle of the head

light .....3-39

Angle adjustment levels of the

head light ..... 3-39

Angle adjustment standard for

the head light ..... 3-40

Daytime Running Light (DRL)\* .....3-40

In case the DRL turns on ..... 3-40

In case the DRL turns off ..... 3-41

Smart High Beam (SHB)\* .....3-41

Setting the SHB ..... 3-41

In case the high beam turns on ··· 3-42

In case the high beam turns off ··· 3-42

Operating the Light switch ..... 3-42

AUTO Approach .....3-43

In case the auto approach lamp

turns off ..... 3-43

Coming home/living home light ···3-44

Setting the coming home/living

home light ..... 3-44

Operating the coming home light · 3-44

Operating the living home light ··· 3-44

Auto light function\* .....3-45

Auto light sensor ..... 3-45

Interior lamp .....3-46

Front room lamp (overhead

console) .....3-47

Driver seat spot switch ..... 3-47

Front passenger seat spot

switch ..... 3-47

Driver / passenger / center room

lamp spot switch ..... 3-47

Door linkage switch ..... 3-47

Front spot lamp ..... 3-47

Linkage function between the  
smart/reakes key and the front room  
lamp ..... 3-47

Center room lamp .....3-48

Luggage room lamp .....3-48

Sun visor/mirror lamp .....3-48

Glove box lamp .....3-49

Mood lamp\* .....3-49

Mood lamp setting ..... 3-49

e-call (Emergency call)\* .....3-50

How to use E-CALL system ..... 3-50

e-call can't be canceled when ..... 3-52

**Wiper and washer fluid ..... 3-54**

Windshield wiper .....3-54

Adjusting the operation speed of

the windshield wiper .....3-54

Front windshield and washer fluid

linkage .....3-54

Front auto washer .....3-54

Rear window wiper .....3-55

Rear window wiper washer fluid

linkage function .....3-55

Rain sensing wiper\* .....3-55

Rain sensor .....3-55

**Mirror ..... 3-56**

Outside rearview mirror .....	3-56	Driver/Passenger Side Temperature Control .....	3-63	Buttonless Integrated Control Panel Screen Off .....	3-71
Folding/unfolding the outside rearview mirror .....	3-56	Independent Temperature Control (SYNC Off) .....	3-63	Vehicle settings switch .....	3-71
Auto folding/unfolding function .....	3-56	Temperature Synchronization Control (SYNC On) .....	3-64	Buttonless Integrated Control Panel Favorites .....	3-72
Adjusting the outside rearview mirror .....	3-56	AUTO Mode .....	3-64	How to set Favorites menu .....	3-72
Selecting the outside rearview mirror .....	3-56	Manual Mode .....	3-65	Buttonless Integrated Control Panel Reset .....	3-72
Adjusting the angle of the outside rearview mirror .....	3-57	Air Distribution .....	3-66	How To Reset .....	3-72
Interior mirror .....	3-57	Activating glass heater .....	3-66	<b>Steering wheel .....</b>	<b>3-73</b>
ECM room mirror* .....	3-57	How to Dehumidify Window Glass .....	3-67	Adjusting the height/length of the steering wheel .....	3-73
Manual type inside rearview mirror .....	3-58	Auto Defogger System (ADS) .....	3-68	Steering wheel heater* .....	3-73
Manual Day/Night Adjustment .....	3-58	Operation levels of auto defogger system .....	3-68	Horn .....	3-74
<b>Heater and air conditioner .....</b>	<b>3-59</b>	Eco Mode .....	3-68	<b>Infotainment system .....</b>	<b>3-75</b>
Adjusting the direction of air distribution and blocking the air distribution .....	3-59	<b>Activating glass heater .....</b>	<b>3-69</b>	Smart audio* .....	3-75
Rear air distribution and fan speed control .....	3-60	Switch Between Buttonless Integrated Control Panel Screens .....	3-69	AV/Navigation .....	3-76
Cautions for using the heater and air conditioner .....	3-60	Buttonless Integrated Control Panel Screen Composition .....	3-70	Slots for multimedia .....	3-76
Replacing A/C refrigerant/oil .....	3-60	Items to be displayed at all times .....	3-70	Operating from the steering wheel .....	3-77
Heater & A/C Controls .....	3-62	Heater and A/C control (FATC) screen .....	3-70	Bluetooth hands-free .....	3-77
Turning Heater and A/C On/Off .....	3-63	Front seat heating / ventilation control screen .....	3-70	Mute .....	3-77
				Controlling the volume .....	3-77
				Searching for media (SEEK) .....	3-77
				Selecting the mode .....	3-78

Voice recognition function .....	3-78
Antenna .....	3-78
<b>USB charging port .....</b>	<b>3-79</b>
<b>Power socket .....</b>	<b>3-80</b>
<b>Indoor convenient equipment ..</b>	<b>3-81</b>
Sun visor and card holder (driver seat) .....	3-81
Sun visor .....	3-81
Card holder .....	3-81
Mirror and lamp .....	3-81
Grip handle/coat hanger .....	3-82
Rear seat door roller blind* .....	3-82
<b>Storage unit .....</b>	<b>3-83</b>
Front seat/rear seat cup holder* .....	3-83
Front storage (W/O WPC) .....	3-83
Front side storage box .....	3-84
Rear storage box .....	3-84
Glove box .....	3-84
Console .....	3-85
Door map pocket .....	3-85
Seat backrest pocket .....	3-86
Wireless Phone Charger System* .....	3-86

To Charge Phone .....	3-86
<b>Additional equipment in the luggage compartment* .....</b>	<b>3-89</b>
Luggage upper cover .....	3-89
Installing the luggage upper cover ..	3-89
How to store luggage upper cover ..	3-89
Luggage compartment .....	3-90
<b>Roof rack* .....</b>	<b>3-91</b>

## 4. Starting and driving

<b>START/STOP switch (Smart key)*</b>	<b>4-2</b>
OFF status .....	4-2
ACC status .....	4-2
ON status .....	4-2
READY status .....	4-2
Starting the engine .....	4-3
Starting the engine .....	4-3
Restarting the engine when it cannot be started .....	4-3
Stopping the engine .....	4-4
Stopping the engine while driving (in the event of emergency) .....	4-4

System safety mode .....	4-4
Cautions for using the START/STOP switch .....	4-5
<b>Key cylinder (ignition key) .....</b>	<b>4-6</b>
OFF position (LOCK) .....	4-6
ACC position .....	4-6
ON position .....	4-6
START position .....	4-6
Starting the engine .....	4-7
Starting the engine .....	4-7
Restarting the engine when it cannot be started .....	4-7
Stopping the engine .....	4-8
System safety mode .....	4-8
<b>Smart key* &amp; REKES key .....</b>	<b>4-10</b>
Function of each button .....	4-10
Locking the door .....	4-10
Unlocking the door (when the safety unlock is enabled) .....	4-11
Unlocking the door (when the safety unlock is disabled) .....	4-12
Opening/closing the tailgate (A type) .....	4-12



Activating/deactivating the panic mode (B type) .....	4-12	Replacing the smart key/rekes key battery .....	4-19	Electric power steering warning light .....	4-27
Additional functions .....	4-13	<b>Instrument cluster .....</b>	<b>4-21</b>	Parking brake ON indicator (red) .....	4-27
Smart door auto lock (auto close) .....	4-13	Driving Information Display .....	4-22	ABS (Anti-Lock Brake System) warning light .....	4-28
Activating the smart door auto lock function (Activating from the instrument cluster) .....	4-13	Engine RPM .....	4-22	Brake warning lamp .....	4-28
Activating the smart door auto lock function (Activating with the smart key) .....	4-13	Driving Speed .....	4-22	Electronic Parking Brake (EPB) warning light .....	4-29
Locking/unlocking the door with the door handle switch .....	4-14	Over speed warning light (GCC only) .....	4-22	AUTO HOLD indicator/warning light .....	4-29
To lock with door handle switch .....	4-14	Engine Coolant Temperature .....	4-22	Engine check indicator .....	4-29
To unlock with door handle switch (when the safety unlock is disabled) .....	4-14	Fuel gauge .....	4-23	Steering wheel heater indicator* .....	4-30
To unlock with door handle switch (when the safety unlock is enabled) .....	4-15	Total mileage .....	4-23	Electronic stability control system (ESC) ON indicator/warning light .....	4-30
Cautions for using smart key / REKES key .....	4-16	Position of gear shift lever .....	4-24	Electronic stability control system (ESC) OFF indicator .....	4-30
Using the emergency key .....	4-17	Gear position display in D (automatic) mode .....	4-24	Low fuel level warning light .....	4-31
Unfolding/folding the emergency key .....	4-17	Gear shift point indicator in manual mode .....	4-24	Global warning light .....	4-31
Locking/unlocking the door using the emergency key .....	4-17	Manual transmission display .....	4-24	Autonomous Emergency Braking (AEB) warning light .....	4-31
Starting the engine with the dead smart key or interference, etc. (in the event of emergency) .....	4-19	Warning lights and indicators .....	4-25	Autonomous Emergency Braking (AEB) OFF indicator .....	4-32
		Seat belt warning lamp .....	4-25	Hill Descent Control (HDC) ON indicator/warning light .....	4-32
		Air bag warning lamp .....	4-25	LKA (LDW) indicator / warning lamp* .....	4-32
		Engine oil pressure warning light .....	4-25		
		Charge warning light .....	4-26		
		Immobilizer/smart key warning light .....	4-26		
		Engine overheat warning lamp .....	4-26		

Centering lane keeping assist (CLKA) indicator / warning lamp	4-33	Mileage/average speed/driving time	4-40	<b>Gear selector lever in automatic transmission*</b>	<b>4-95</b>
Illumination ON indicator	4-33	Driving information after departure	4-41	Paddle shift (-/+)	4-95
Front fog lamp ON indicator*	4-33	ISG cumulative time	4-41	Shift Lock	4-96
Rear fog lamp ON indicator*	4-33	Media Display	4-41	Operation procedures for shift lock	4-96
SHB indicator*	4-33	TPMS status	4-42	P (parking) position	4-97
High beam indicator	4-34	Driving assist Menu	4-42	R (reverse) position	4-97
Turn signal/hazard warning lamp	4-34	Driving assist	4-42	N (neutral) position	4-97
WINTER / SPORT indicator lamp	4-35	Driver attention alert	4-42	D (driving) position	4-98
Hands OFF warning lamp*	4-35	User settings	4-43	+/(manual) position	4-99
ISG indicator/warning lamp*	4-35	Message on the display of the instrument cluster	4-48	Shifting	4-99
ISG OFF indicator*	4-36	<b>Instrument cluster illumination brightness</b>	<b>4-91</b>	Using the engine brake	4-101
4WD CHECK warning lamp*	4-36	To Adjust Instrument Cluster Illumination Brightness	4-91	If the gear shift lever cannot be moved from the P (parking) position to another position	4-101
4WD LOCK ON indicator*	4-36	<b>Shift lever in manual transmission</b>	<b>4-92</b>	<b>Driving a vehicle equipped with automatic transmission</b>	<b>4-102</b>
Over speed warning light (GCC only)	4-37	Downshifting	4-93	Using the engine brake	4-103
Door open warning light	4-37	Gear position when parking	4-93	Using the kick down function	4-104
Master symbol	4-37	Using the clutch	4-93	Safety mode of the automatic transmission	4-104
<b>Indicator panel on instrument cluster</b>	<b>4-38</b>	Driving tips for normal starting off or starting off on uphill	4-93	Resetting the safety mode when the gear shift lever is fixed to a position	4-104
Main menu	4-38	EPB operation when driving uphill	4-94		
Main menu list	4-39				
Trip computer information	4-39				
Distance to empty/average fuel economy/Instantaneous fuel economy	4-39				

Cautions for using a vehicle equipped with automatic transmission	4-105	Cruise Control Ready / Enabled Display	4-113	Temporary acceleration (override)	4-120
<b>4WD System*</b>	<b>4-106</b>	Setting the cruise control driving speed	4-113	Deactivating	4-121
4WD LOCK Shift	4-106	Speed acceleration process of the cruise control	4-114	Disable conditions	4-121
Driving Modes and Indicators	4-106	Speed deceleration of the cruise control	4-115	Other disable conditions	4-121
4WD LOCK indicator (green)	4-106	Deactivating the cruise control	4-116	Resume	4-122
4WD CHECK warning lamp (red)	4-106	Deactivation condition	4-116	To Deactivate	4-122
Driving Modes	4-107	Other deactivation conditions according to the vehicle condition	4-116	Steering wheel (steering force) control alert	4-123
Cautions for using 4WD system	4-107	Resuming the cruise control	4-117	To set safety distance to front vehicle	4-125
<b>ISG (Idle Stop &amp; Go) System* ..</b>	<b>4-109</b>	<b>Intelligent / Adaptive Cruise Control*</b>	<b>4-118</b>	Forward situation awareness	4-126
Engine Automatic Shutdown	4-109	Intelligent Cruise Control Ready / Enabled Display	4-118	Starting at congested areas	4-126
Automatic Engine Restart	4-109	Set intelligent cruise (enabled)	4-118	Front detection sensor (Front radar + front camera)	4-126
ISG system OFF	4-110	Intelligent Cruise Control Ready	4-118	Vehicle detection is difficult under the following circumstances:	4-127
Conditions for ISG system activation	4-110	To enable intelligent cruise control at instrument cluster	4-119	Not detected preceding pedestrian	4-128
Forced restart conditions	4-110	To set intelligent cruise control	4-119	Curved road	4-128
Battery sensor (BSC)	4-111	Increasing speed	4-120	Uphill or downhill	4-129
Conditions for activating battery sensor (BSC)	4-111	Decreasing speed	4-120	To change lane	4-129
<b>Cruise control system</b>	<b>4-112</b>			Detecting vehicle ahead	4-130
Conditions for using the cruise control	4-112			<b>Speed Limit*</b>	<b>4-131</b>
Cruise control switch and indicator	4-112			Images that show readiness and operation	4-131
Cruise control switch	4-112				

Speed limit ready .....	4-131	ESC indicator/warning light .....	4-139	AUTO HOLD indicator/warning	
To set speed limit .....	4-131	ESC OFF indicator .....	4-139	light .....	4-147
How to enable speed limit in		Phenomenon that occurs when the		<b>Autonomous Emergency Braking</b>	
instrument cluster .....	4-132	ESC is activated .....	4-140	<b>(AEB)* .....</b>	<b>4-148</b>
To Turn Speed limit ON/OFF .....	4-132	When it is necessary to deactivate		AEB indicator/warning light .....	4-148
To set speed .....	4-132	the ESC function .....	4-140	AEB OFF indicator .....	4-148
To deactivate speed limit warning .....	4-132	Hill Descent Control (HDC) .....	4-141	AEB indicator/warning light .....	4-148
<b>Brake system .....</b>	<b>4-134</b>	Activating/deactivating the HDC		AEB is activated .....	4-149
Foot brake .....	4-135	function .....	4-141	Setting the sensitivity of the forward	
Checking for foreign materials on		HDC indicator/warning light .....	4-142	collision warning .....	4-149
the pedal operation area .....	4-135	HDC activation conditions .....	4-142	AEBS operation .....	4-150
Checking and replacing the brake		HDC deactivation conditions .....	4-142	Activation conditions .....	4-151
pads/discs .....	4-136	HDC operation .....	4-142	Deactivation conditions .....	4-151
If the brake is not working .....	4-136	Electronic Parking Brake (EPB) .....	4-143	The AEB cannot detect a vehicle	
ABS (Anti-Lock Brake System) .....	4-136	Applying the EPB .....	4-143	properly: .....	4-151
ABS warning light .....	4-137	Releasing the EPB .....	4-143	The AEB cannot detect a	
Electronic Brake-Force Distribution		Releasing the EPB		pedestrian .....	4-154
(EBD) .....	4-137	automatically .....	4-144	<b>Rear and side warning</b>	
Brake warning lamp .....	4-137	EPB warning light/brake warning		<b>system* .....</b>	<b>4-156</b>
Emergency Stop Signal (ESS) .....	4-138	light .....	4-144	Display of rear and side warning	
Activation and deactivation		EPB emergency mode .....	4-144	system activation .....	4-156
conditions .....	4-138	AUTO HOLD .....	4-146	Warning Steps in BSW System .....	4-157
Electronic stability control system		To Set / Deactivate AUTO HOLD		When the rear and side warning	
(ESC) .....	4-139	Function .....	4-146	system is abnormal .....	4-157
		Using the AUTO HOLD function .....	4-146		

Blind Spot Detection Warning (BSW) system .....	4-158
Activating / deactivating BSW system .....	4-158
Activation conditions .....	4-158
Lane Change Warning (LCW) system .....	4-159
Operating conditions .....	4-159
BSA System .....	4-159
Activating / deactivating BSA system .....	4-159
Operating conditions .....	4-160
BSA is deactivated when: .....	4-160
RCTW System .....	4-160
Activating / deactivating RCTW system .....	4-161
Activation conditions .....	4-161
RCTA System .....	4-162
Activating / deactivating RCTA system .....	4-162
Operating conditions: .....	4-162
Cases where RCTA system not work .....	4-163
Cases where the RCTA system malfunctions .....	4-163

SEW System .....	4-164
Activating / deactivating SEW system .....	4-164

### **LDW (Lane Departure Warning)\* .....**

To activate / deactivate lane departure warning (LDW) .....	4-165
LDW ON indicator .....	4-166
Activation conditions .....	4-166
Cases that the system is not activated .....	4-167
Cases requiring the driver's attention .....	4-168

### **LKA (Lane Keeping Assistance)\* .....**

To activate / deactivate lane keeping assistance (LKA) .....	4-169
LKA ON indicator .....	4-170
Operating conditions .....	4-170
Cases that the system is not activated .....	4-171
Cases requiring the driver's attention .....	4-172

### **ELK (Emergency Lane Keeping)\* .....**

RKA-ROADEDGE (Lane Keeping Assist-Roadedge) .....	4-173
Activation / Deactivation .....	4-173
Operating conditions .....	4-173
Does not work when: .....	4-174
Driver Attention Required .....	4-175

### **Centering Lane Keeping Assist (CLKA) .....**

To activate / deactivate CLKA .....	4-176
Centering lane keeping assist (CLKA) ON indicator lamp .....	4-177
Conditions for activation .....	4-177
The CLKA does not work when: .....	4-178
Driver Attention Required .....	4-179

### **FVSW (Front Vehicle Start Warning)\* .....**

How To Set .....	4-181
Operation .....	4-181

### **Parking assist system\* .....**

Front/rear obstacle detection system .....	4-182
Activating the obstacle detection system .....	4-183

Warning buzzer interval .....	4-184
Sensor and relevant system malfunction .....	4-184
If the system does not operate or malfunctions .....	4-185
Cautions regarding the front/rear obstacle detection system .....	4-186
Rear camera system .....	4-186
<b>Double parking (2-row parking)</b>	<b>4-188</b>
Vehicles With EPB .....	4-188

## 5. Emergency Measures in the Event of Emergency

<b>Warning triangle and OVM (Owner Vehicle Maintenance) tools</b> .....	<b>5-2</b>
Warning triangle .....	5-2
Storage place of the warning triangle* .....	5-2
OVM tools .....	5-2
Location where the OVM tools are stored .....	5-3

### When the engine cannot be started due to depletion of the battery .....

Starting the engine using the jump cable .....	5-4
--	-----

### When the engine is overheated or other problems have occurred ...

When the engine is overheated so that the warning light turns on .....	5-6
Symptoms that appear when the engine is overheated .....	5-6
Emergency measures when the engine is overheated .....	5-6
When the engine check indicator turns on .....	5-7

### When a tire is flat .....

Repairing a flat tire/inflating a tire using the service kit for tire repair .....	5-9
Components of the service kit for tire repair* .....	5-9
Storage location of the service kit ...	5-9
Confirming whether it is possible to repair the flat tire with the service kit or not .....	5-9
Operating principle of the service kit .....	5-10

Repairing a flat tire .....	5-10
Inflating a tire .....	5-15
Removing the spare tire (Temporary)* .....	5-16
Changing a spare tire (Temporary) ...	5-17
When replacing a front tire .....	5-17
When replacing a rear tire .....	5-18
Cautions when changing the tire .....	5-20

### When you need to have your vehicle towed .....

Towing a disabled vehicle .....	5-21
Towing with tow truck .....	5-21
For 4WD vehicle .....	5-21
For 2WD vehicles .....	5-21
When a tow truck is unavailable (in case of emergency) .....	5-22
Installing the towing hook .....	5-22
Using a towing rope .....	5-23
Trailer towing .....	5-24
Trailer loading .....	5-24
Maximum Load Limits .....	5-24
If you want to pull a trailer .....	5-25
Weight of trailer .....	5-25
Weight of trailer tongue .....	5-25

Trailer brakes .....	5-26
Trailer lights .....	5-26
Tires .....	5-26
Safety chains .....	5-26
Brake fluid .....	5-26
Automatic transmission fluid .....	5-26
Towing tips .....	5-26
Driving on hill .....	5-27
Parking on hills .....	5-27
When you are ready to leave after parking on a hill .....	5-27
Maintenance when towing trailer .....	5-27

**When the vehicle has stopped  
due to a failure ..... 5-28**

**In the event of an accident ..... 5-29**

Tips when an accident or a malfunction occurs on the expressway .....	5-29
---	------

**In the event of a fire ..... 5-30**

Placing an extinguisher in the vehicle .....	5-30
How to use the extinguisher .....	5-30
Checking and maintaining the extinguisher .....	5-30

**In the event of a heavy snow ..... 5-31**

**6. Periodic Checking and  
Maintenance**

**Scheduled maintenance services  
- gasoline engine ..... 6-2**

**Scheduled maintenance services  
(under severe condition) -  
gasoline engine ..... 6-5**

**Checking the engine room ..... 6-8**

**Engine oil ..... 6-9**

Level Check .....	6-9
Replenishment .....	6-9
Function of engine oil .....	6-10
Consumption of Engine Oil .....	6-10

**Engine care ..... 6-10**

**Change interval ..... 6-11**

**Specification and capacity ..... 6-11**

**Warnings and cautions when  
checking ..... 6-11**

**Engine ..... 6-12**

**SAE viscosity classes ..... 6-12**

**Engine coolant ..... 6-13**

Level Check .....	6-13
Service Interval .....	6-13

Replenishment .....	6-13
<b>Air cleaner ..... 6-15</b>	
Cleaning .....	6-15
Change .....	6-16

**Brake and clutch fluid  
(with M/T) ..... 6-17**

Specification and Replacement .....	6-17
Level Check and Replenishment .....	6-17

**Washer fluid ..... 6-18**

Top up washer fluid .....	6-18
---------------------------	------

**Battery ..... 6-19**

Battery Maintenance .....	6-19
Specification .....	6-19

**Spark plugs - Gasoline  
engine ..... 6-21**

**Checking the wipers and  
replacing the blade ..... 6-22**

Replacing the blade of windshield wiper .....	6-22
Replacing the blade of rear window wiper .....	6-22
Specifications of wiper blade .....	6-22

**Checking and replacing fuses and relays** ..... 6-24

- Engine compartment fuse and relay box ..... 6-24
- Interior fuse box ..... 6-24
- Checking and replacing fuses ..... 6-25

**Checking and replacing the lamps** ..... 6-26

- Specifications of lamps and checking ..... 6-26
  - Specifications and quantity of lamps and bulbs ..... 6-26
  - Checking the lamps ..... 6-27
  - Headlamp desiccant\* ..... 6-27
- Position of exterior lights and lamps ..... 6-28
- Replacing exterior lamps ..... 6-29
  - Replacement of headlamp desiccant ..... 6-29
  - Headlamp absorbent\* ..... 6-29
  - To replace license plate lamp ..... 6-29
  - To Replace Rear Combination Lamp ..... 6-30
- Position of interior lamps ..... 6-32
- Replacing the interior lamps ..... 6-33
  - Center Room Lamp (Bulb) ..... 6-33

- Replacing the sun visor/mirror lamp (Bulb) ..... 6-33
- Glove Box Lamp ..... 6-34

**Replacing the A/C filter** ..... 6-35

**Checking the tires and wheels** ..... 6-37

- Checking the tire pressure ..... 6-37
- Prescribed tire inflation pressure ..... 6-37
- Wheel alignment status and the balance between tires and wheels ..... 6-37
- Checking the status of tire wear ..... 6-38
- Rotating the tire positions ..... 6-38
- Snow tire ..... 6-38
- Tire chain ..... 6-39
- Cautions for checking the tires and wheels ..... 6-39

**Vehicle management during winter** ..... 6-41

- Starting the engine and driving the vehicle ..... 6-41
- Managing the engine oil ..... 6-41
- Managing the engine coolant ..... 6-41
- Managing washer fluid ..... 6-41
- Installing a snow tire ..... 6-41

- Managing the A/C ..... 6-42
- Other maintenance ..... 6-42
- Cautions for parking during winter ..... 6-43

**Warnings for self-maintenance** · 6-44

**7. Index**



# Table of Pictures

Find the desired information using a picture easily even if you do not know the title of the desired information.

## Front section

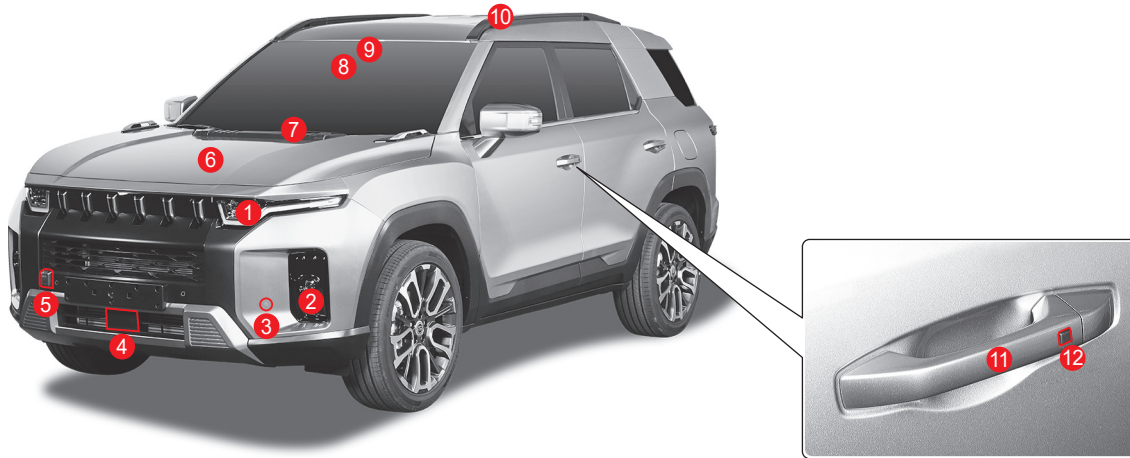

1 Head light (head light).....3-37	7 Windshield wiper .....3-54	9 Auto light/rain sensor.....3-45/3-55
• Smart High Beam (SHB) .....3-41	8 Front camera module (FCM).....4-126	10 Roof rack .....3-91
• Daytime running light (DRL) .....3-40	• Autonomous Emergency Braking (AEB).....4-148	11 Door handle.....4-14, 4-17
2 Front fog light .....3-37	• Lane Departure Warning (LDW).....4-165	• Using emergency key .....4-17
3 Front obstacle detection sensor.....4-182	• Lane Keeping Assist (LKA) .....4-169	12 Door outside handle switch.....4-14
4 Front radar .....4-126	• Centering Lane Keeping Assist (CLKA).....4-176	
• Intelligent cruise control .....4-118	• Front Vehicle Start Warning (FVSW).....4-181	
5 Front towing hook .....5-22		
6 Engine hood .....3-33		

## Rear section

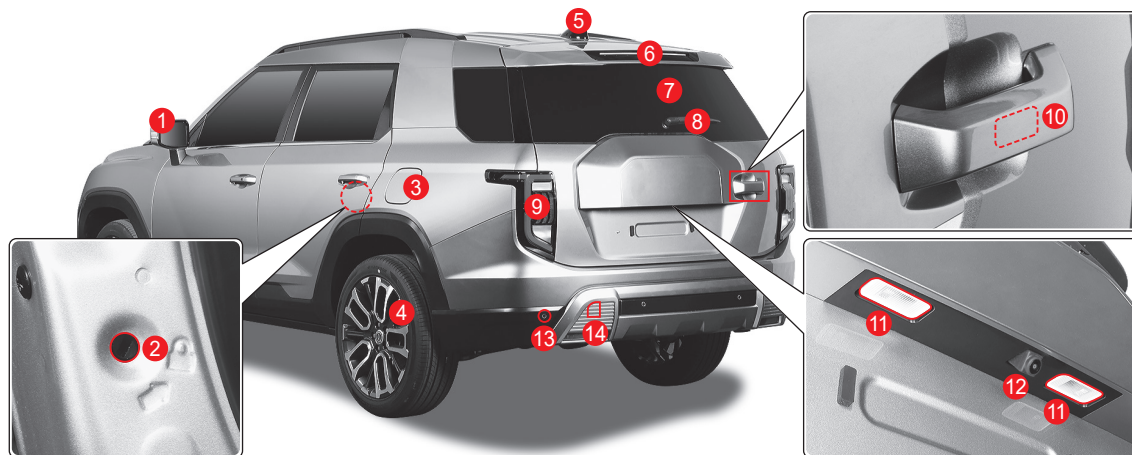

1	External mirror heater	3-66
2	Child safety door lock / unlock	3-5
3	Fuel inlet	3-34
4	Tire and wheel	6-37
	• Tire pressure monitoring system (TPMS)	2-29

5	Antenna (GPS, radio)	3-78
6	High mounted stop lamp	3-72
7	Rear window heater	3-66
8	Rear window wiper	3-55
9	Rear lamp	3-36, 6-26, 6-28

10	Tailgate open button	3-25
11	License plate lamp	3-62
12	Rear camera	4-186
13	Rear obstacle detection sensor	4-182
14	Rear towing hook	5-22

## Driver door and steering wheel section

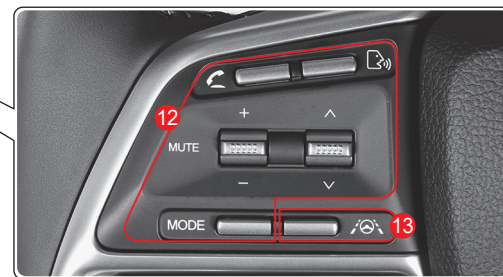
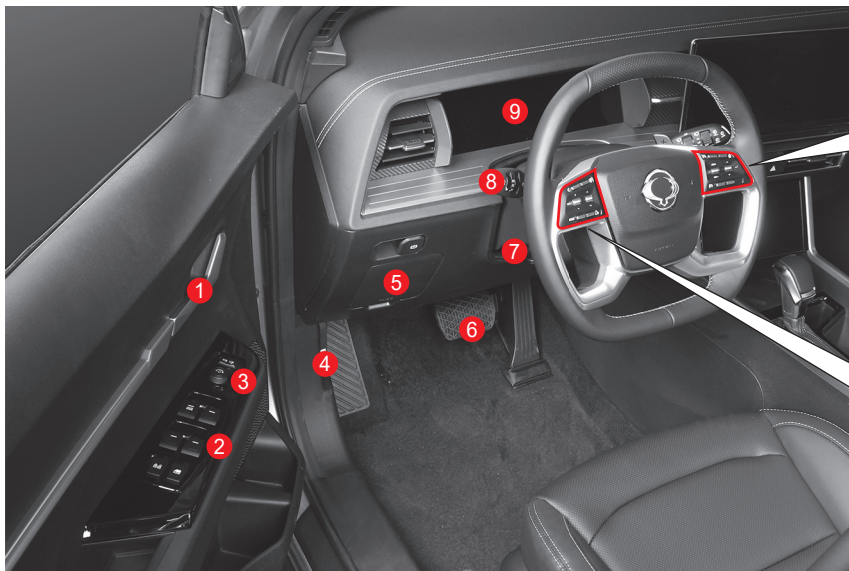

- |  |  |  |
|--|--|--|
| 1 Driver door open lever ..... 3-36              | 6 Foot brake ..... 4-135                                   | 10 Cruise control switch ..... 4-112   |
| 2 Window button ..... 3-18                       | • Emergency stop signal (ESS) ..... 4-138                  | 11 Instrument cluster menu and control buttons ..... 4-38                                  |
| 3 Outside mirror angle control switch ..... 3-56 | 7 Steering wheel telescoping/tilt control lever ..... 3-73 | 12 Audio system control button ..... 3-77  |
| 4 Engine hood opening lever ..... 3-33           | 8 Light switch ..... 3-37                                  | 13 Lane departure warning (LDW) switch/ Lane keeping assist (LKA) switch ..... 4-165/4-169 |
| 5 Interior fuse box ..... 6-24                   | 9 Instrument cluster ..... 4-21                            |  |

## Interior front view

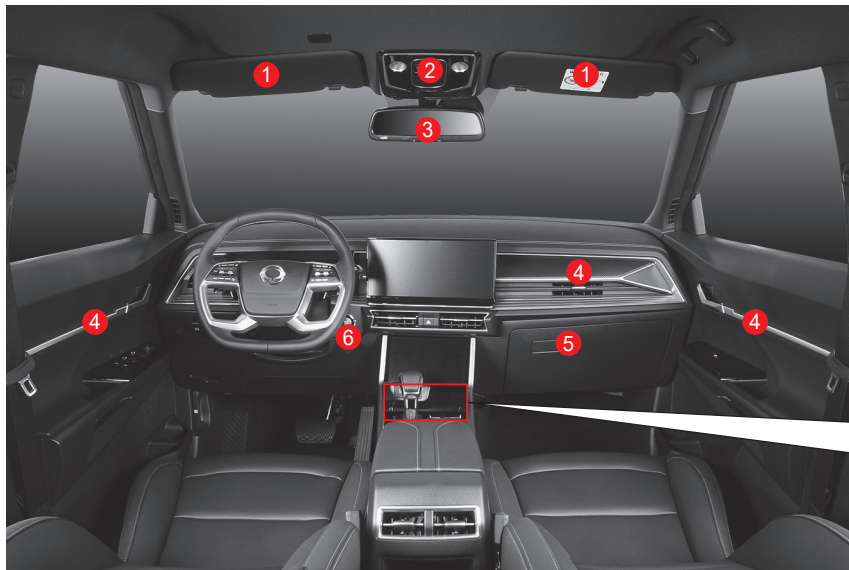

- |                                      |  |  |
|--------------------------------------|--|--|
| 1 Sun visor.....3-81                 | 3 Inside rear view mirror.....3-57                       | 6 START/STOP switch.....4-2                      |
| 2 Overhead console assembly.....3-47 | 4 Mood lamp (front door & passenger<br>IP side).....3-49 | 7 Automatic transmission selector lever.....4-95 |
| • Sunroof control switch.....3-22    | 5 Glove box.....3-84                                     | 8 USB port.....3-76                              |
| • Front room lamp.....3-47           |  | 9 Wireless phone charger system.....3-86         |
| • E-call.....3-50                    |  |  |

## Interior front view (Buttonless integrated control panel)

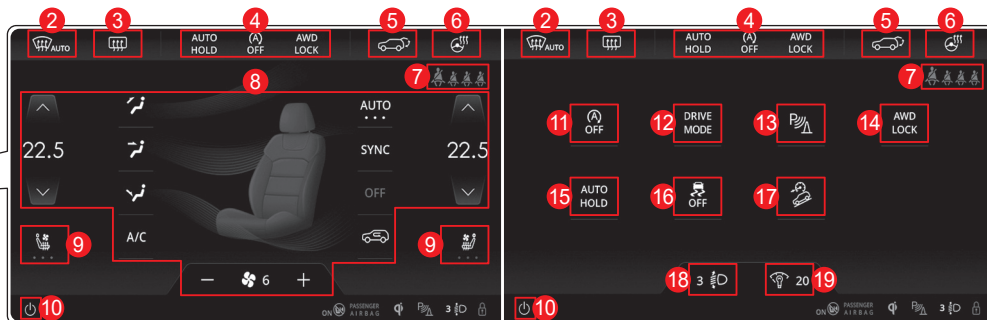
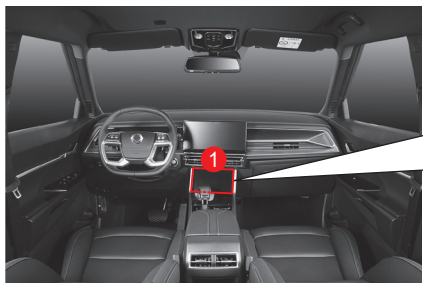

- |   |   |    |   |    |  |
|---|---|----|---|----|--|
| 1 | Buttonless integrated control panel configuration ..... 3-69    | 7  | Seat belt reminder warning lamp ..... 2-2       | 13 | Front obstacle detection ON/OFF switch ..... 4-182 |
| 2 | Dehumidify window glass (Auto defogger system) ..... 3-67, 3-68 | 8  | Heater and A/C controller ..... 3-62            | 14 | AWD LOCK switch ..... 4-106                        |
| 3 | Glass heater switch ..... 3-66                                  | 9  | Front seat heater/ventilation switch ..... 3-14 | 15 | AUTO HOLD switch ..... 4-146                       |
| 4 | Favorite menu ..... 3-72  | 10 | LTCM screen OFF switch ..... 3-70               | 16 | ESC OFF switch ..... 3-71                          |
| 5 | Tailgate interior switch ..... 3-26                             | 11 | ISG OFF switch ..... 4-109                      | 17 | HDC switch ..... 4-141                             |
| 6 | Steering wheel heater switch ..... 3-73                         | 12 | Driving mode switch ..... 3-71                  | 18 | Headlamp leveling switch ..... 3-71                |
|   |   |    |   | 19 | Interior illumination control switch ..... 3-71    |

## Rear seats



1	Rear seat	3-11
2	Baby car seat	2-11
3	Rear seat door open lever	3-36
4	Rear seat window button	3-19
5	Rear seat warmer button	3-16
6	USB charging port	3-79
7	Rear cup holder and armrest	3-83
8	Rear seat belt	2-6
9	Rear seatback release lever	3-12

## Luggage compartment

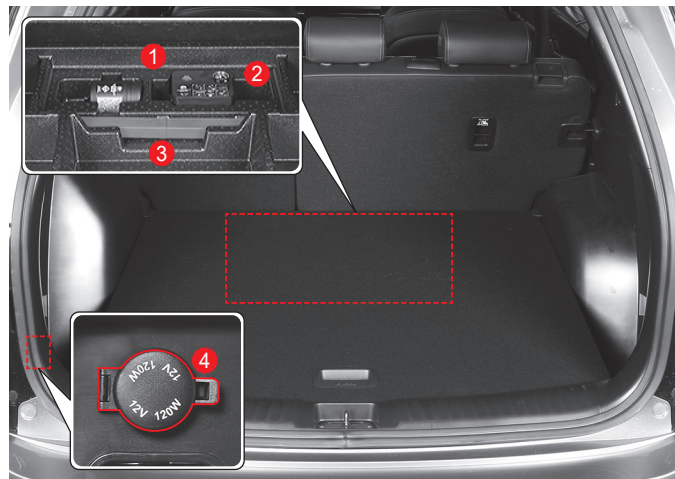

1	Service kit for tire repair	5-9
2	OVM tools	5-2
3	Warning triangle	5-2
4	Power socket (left side of luggage compartment)	3-80

## Engine room

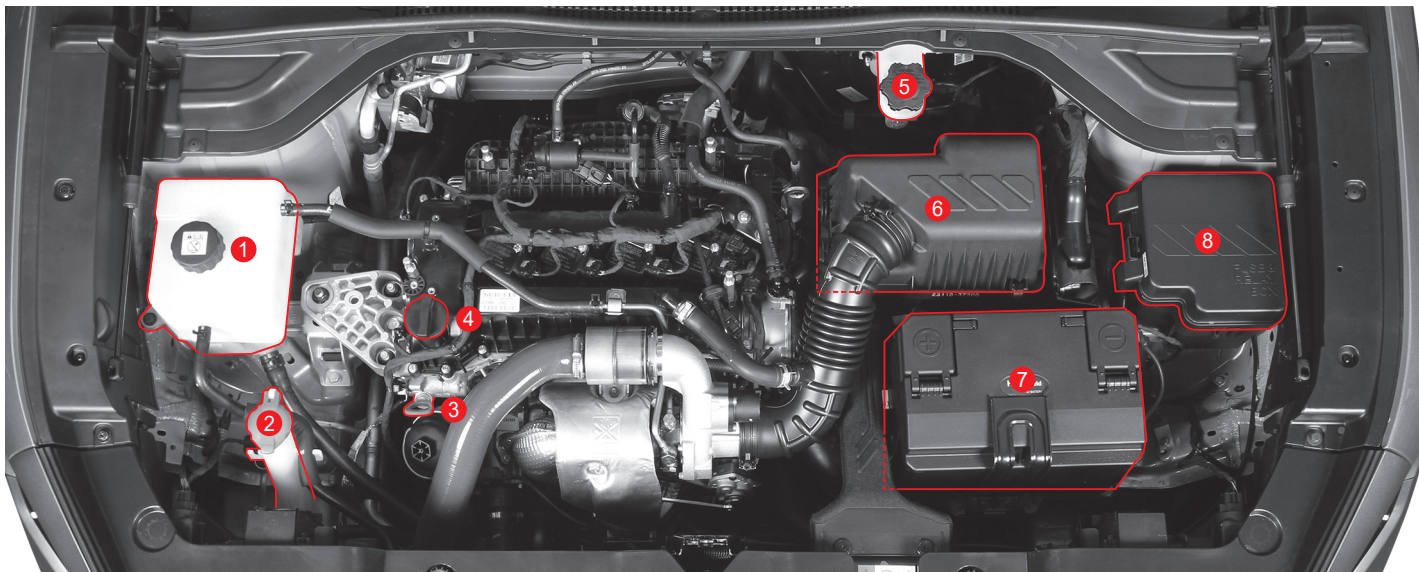

- |   |  |   |
|---|--|---|
| <b>1</b> Engine coolant reservoir ..... 6-13  | <b>4</b> Engine oil inlet ..... 6-9                            | <b>7</b> Battery ..... 6-19                               |
| • Checking engine coolant ..... 6-13          | • Adding and replacing engine oil ..... 6-9                    | • Checking and replacing the battery ..... 6-19           |
| <b>2</b> Washer fluid inlet ..... 6-18        | <b>5</b> Brake and clutch fluid reservoir ..... 6-17           | <b>8</b> Engine compartment fuse and relay box ..... 6-24 |
| • Checking and adding washer fluid ..... 6-18 | • Checking brake and clutch fluid ..... 6-17                   | • Checking and replacing fuses ..... 6-25                 |
| <b>3</b> Engine oil level gauge ..... 6-9     | <b>6</b> Air cleaner ..... 6-15                                |   |
| • Checking engine oil ..... 6-9               | • Cleaning the air cleaner and replacing the filter ..... 6-15 |   |

## Warning lights and indicators









Image	Meaning/Relevant page
	Seat belt warning lamp ..... 2-2, 4-25
	Air bag warning lamp ..... 2-20, 4-25
	Global warning light ..... 4-31
	Immobilizer/Smart key warning light ..... 2-35, 4-26
	Engine oil pressure warning light ..... 4-25
	Charge warning light ..... 4-26
	Engine overheat warning lamp ..... 4-26
	SSPS warning lamp ..... 4-27









Image	Meaning/Relevant page
	Brake warning lamp ..... 4-27, 4-137
	ABS (Anti-Lock Brake System) warning light ..... 4-28, 4-137
	Parking brake ON indicator (red) ..... 4-27, 4-137
	Electronic parking brake (EPB) warning lamp (orange) ..... 4-29, 4-143
	Engine check indicator ..... 4-29, 5-7
	Steering wheel heater indicator ..... 4-30
	Electronic stability control system (ESC) ON indicator/ warning light ..... 4-30, 4-139
	ESC OFF indicator ..... 4-30, 4-139









Image	Meaning/Relevant page
	Low fuel level warning light ..... 4-31
	Autonomous Emergency Braking System (AEBS) warning light ..... 4-31, 4-148
	AEBS OFF indicator ..... 4-32, 4-148
	Illumination ON indicator ... 4-33
	Front fog light ON indicator ..... 4-33
	SHB indicator ..... 4-33
	High beam indicator ..... 4-34
	Turn signal/hazard warning lamp ..... 4-34













Image	Meaning/Relevant page
	Hands-off warning lamp ..... 4-35
	Door ajar warning lamp ..... 4-37
<b>AUTO HOLD</b>	AUTO HOLD indicator/warning light ..... 4-29, 4-146
	HDC ON indicator/warning light ..... 4-32, 4-142
	LKAS (LDWS) indicator/warning lamp <ul style="list-style-type: none"> <li>• Lane departure warning (LDW) ..... 4-32, 4-166</li> <li>• Lane keeping assist system (LKA) ..... 4-32, 4-169</li> </ul>
<b>WINTER</b>	Winter mode indicator ..... 4-35
<b>SPORT</b>	SPORT mode indicator ..... 4-35

Image	Meaning/Relevant page
	ISG indicator/warning light ..... 4-35
	ISG OFF indicator ..... 4-36
	4WD CHECK warning light ..... 4-36
	4WD LOCK ON indicator ..... 4-36
	Master symbol ..... 4-37
	Centering lane keeping assist (CLKA) indicator / warning lamp ..... 4-33, 4-176
<b>120 km/h</b>	Over speed (120 km/h) (GCC only) ..... 4-22, 4-37
	Rear fog lamp ON indicator ..... 4-33



# 1. Vehicle Information and Safety Precautions

You can check helpful information for driving and managing the vehicle safely and conveniently.

Information regarding the vehicle identification, specifications, check points before driving the vehicle, safety precautions while driving, and vehicle maintenance methods is provided.

# Information regarding the installation of ADR and provision of information

## **Installation of ADR (Accident Data Recorder) and provision of information**

This vehicle has an ADR (Accident Data Recorder).

The ADR (Accident Data Recorder) is a device that can record and check the driving information of the vehicle (vehicle speed and operation status of brake pedal and acceleration pedal, etc.) for a certain period of time before and after an accident, such as a car crash.

The ADR (Accident Data Recorder) helps to better understand an accident situation.

# Precautions for potentially hazardous seat belt related goods



## Warning

When potentially hazardous seat belt related goods are used, the safety of passengers will be seriously endangered. Never use these goods.

### Do not use the clip to disable the seat belt alarm



When this clip is inserted into the seat belt buckle, the seat belt is recognized as fastened, so the seat belt warning lamp and alarm are not activated.

This leads to no fastening of the seat belt, and it is very dangerous when an accident occurs.

### Do not use the seat belt stopper



When it is installed on the seat belt, it hinders the normal automatic locking function of the retractor and lowers the performance of the seat belt.

### Do not use playroom mat



When it is installed in the rear seat, it will lead to not fastening seat belts and car seats, and it is very dangerous when an accident occurs.

## Precautions for the reduction of non-crash incidents



### Warning

A part of your body may get stuck or hit and get seriously injured when opening and closing the doors. Caution should be taken.



- When you open and close the doors, a part of your body such as your finger or head may get stuck or hit and get seriously injured. Open and close the doors after ensuring that no part of your body is stuck or hit.



- When you open or close the trunk (tail gate), a part of your body such as your finger or head may get stuck or hit and get injured. Open or close the trunk after ensuring safety.
- The trunk (tail gate) is raised or lowered automatically at below or over a certain level. Always take caution to avoid your face or head from getting hit or your hand from getting stuck.



- Close the windows after checking that other passengers' hands or heads are away from the windows. This is especially important for children, who may get a serious injury, such as suffocation if their head gets stuck.
- When you pull the switch continuously to raise the window at a position where something is pinched first without operating the one touch auto close function, the anti-pinch function will not operate.
- Especially when a part of a child's body is on the window, a certain amount of force (resistance) is not applied to the window, so the anti-pinch function may not operate. Make sure to check before closing the windows.

# Cautions for the protection of the environment

KG Mobility Corporation environment-related policies aim at comprehensive protection of the environment. This is also a way to save natural resources that become the basis of human survival on earth, and meet and harmonize the demands of nature and mankind.

## **You can contribute to the protection of the environment by operating our vehicle in an eco-friendly way.**

Fuel consumption, engine speed, transmission control and wear of brakes and tires are influenced by driving conditions and habits.

Observe the following content and participate in the protection of the environment.

### **Driving conditions**

- Avoid short trips since it increases fuel consumption relatively.
- Always check if the tire inflation pressure is appropriate.
- Unload unnecessary goods from the luggage compartment.
- Always check the fuel efficiency.
- Have your vehicle checked periodically.





### **Driving habits**

- Do not depress the accelerator pedal when starting the engine.
- Drive off in the vehicle slowly.
- Keep a safe distance with the vehicle ahead and drive carefully.
- Avoid frequent acceleration or deceleration.
- Avoid sudden acceleration, deceleration, or stops.
- In manual mode, shift the gears properly and avoid exceeding 2/3 of the maximum engine RPM in each gear.
- Avoid warming up the vehicle while stopping.
- Turn off the engine when you stop the vehicle for a long time.

### **Recycling**

- Information about eco-friendly product development and vehicle recycling can be found on the KG Mobility Corporation website [www.kg-mobility.com/en](http://www.kg-mobility.com/en)

## 1. TIRE PRESSURE MONITORING SYSTEM



CE	<p>Hereby, KG Mobility, declares that the in-vehicle mounted radio systems are in compliance with the essential requirements and other relevant provisions of Directive 1999/5/EC</p>	EU
FCC	<p>Model: TSSSG4G5 and TSSRE4Db            FCC ID: OYGTSSRE4DB            ORD. No: 14778/DFRS19614/F-50            This device complies with Part 15 of the Federal Communications Commission (FCC) rules.            Operation is subject to the following two conditions:</p> <ol style="list-style-type: none"> <li>(1) this device may not cause harmful interference, and</li> <li>(2) this device must accept any interference received, including interference that may cause undesired operation.</li> </ol> <div style="border: 1px solid black; background-color: #f4a460; padding: 5px; text-align: center;">  <b>Warning</b> </div> <ul style="list-style-type: none"> <li>• Changes or modifications not expressly approved by the party responsible for compliance could void the user's authority to operate the equipment.</li> </ul>	AMERICA
CU TR	<p>LOGO</p>    <p>Certificate in the user manual due to product size  <b>Tire Pressure Monitoring System</b>  <b>Model: TSSRE4Db</b>            The device passed all the conformity assesment procedures to CU TR.</p>  <p>EAC mark in the user manual due to product size.</p>	CIS



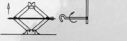

## 2. FOB/FOLDING

<p>FCC</p>	<p>FCC ID: DEO-MT-FLIP01</p> <p>This device complies with Part 15 of the Federal Communications Commission (FCC) rules.</p> <p>Operation is subject to the following two conditions:</p> <ol style="list-style-type: none"> <li>(1) this device may not cause harmful interference, and</li> <li>(2) this device must accept any interference received, including interference that may cause undesired operation.</li> </ol> <div style="border: 1px solid black; background-color: #f9cb9c; padding: 5px; text-align: center;"> <p><b>Warning</b></p> </div> <ul style="list-style-type: none"> <li>Changes or modifications not expressly approved by the party responsible for compliance could void the user's authority to operate the equipment.</li> </ul>	<p>AMERICA</p>
<p>TR</p>	<p>LOGO</p>  <p>Certificate in the user manual due to product size</p>	<p>CIS</p>

## 3. JACK LABEL

<p>CE</p>	<div style="border: 1px solid black; padding: 5px;"> <div style="display: flex; justify-content: space-between;"> <div style="width: 30%;"> <p><b>1</b></p> <p>For use with KORANDO/TORRES model by Ssang Yong Motor Company.</p>  <p>BE SURE TO JACK THE PLACES SHOWN BY ARROWS.</p> </div> <div style="width: 30%;"> <p><b>2</b></p> <p>MECHANICAL SCISSOR JACK</p> <p>Rated load : 1,000kg</p>  <p>Rotate handle to raise or lower. See owner's manual before jacking.</p> </div> <div style="width: 30%;"> <p><b>3</b></p>  <p>Manufacturer : TAEJANG TECHNICAL MFB CO., LTD. Address : 141, Chungcheongdeok-ro, Chungju-si, Chungcheongbuk-do, ZIP CODE 27308 Tel : +82-43-848-1130 MADE IN KOREA Year of Manufacture : Manufacturer's discretion.</p> </div> </div> </div> <div style="border: 1px solid black; background-color: #f9cb9c; padding: 5px; text-align: center; margin-top: 5px;"> <p><b>Caution</b></p> </div> <ul style="list-style-type: none"> <li>When using the jack, set your parking brake.</li> <li>When using the jack, stop the engine.</li> <li>Do not get under a vehicle that is supported by a jack.</li> <li>The designated locations under the frame</li> <li>When supporting the vehicle, the base plate of jack must be vertical under the lifting point.</li> <li>Shift into Reverse gear on vehicles with manual transmission or move the shift lever to the P (Park) position on vehicles with automatic transmission.</li> <li>The jack should be used on firm level ground.</li> </ul>	<p>EU</p>
-----------	---	-----------

## 4. Compressor, Jack

<b>CE</b>	LOGO  (1) Description Model: CE certified parts (2) Representative: KG Mobility European Parts Center B.V. (3) Address: IABC 5253&5254, 4814RD Breda, The Netherlands	EU
<b>UKCA</b>	LOGO  (1) Description Model: UKCA certified parts (2) Importer: KG Mobility UK Ltd (3) Address: G Offices, Parsonage Road, Stratton St. Margaret, Swindon, Wiltshire SN3 4RN	UK



# Dimensions

Front



Top

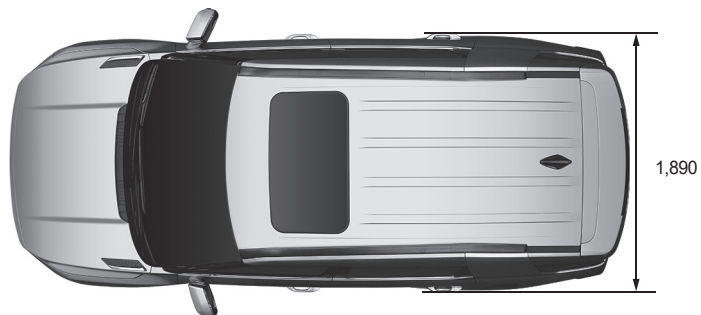

Rear



Side

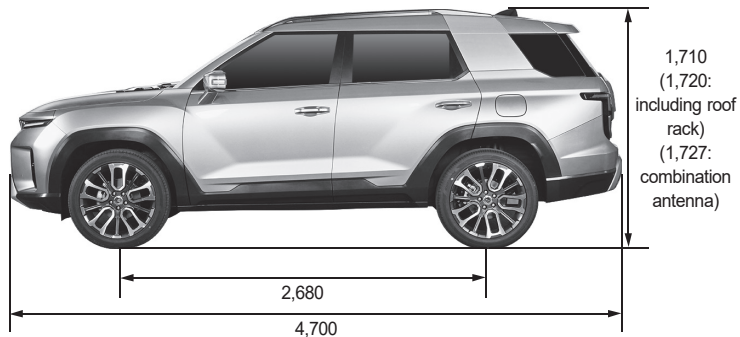

\* ( ): Optional

## SPECIFICATIONS (I)

\* ( ) Optional

Descriptions		Gasoline 1.5 Engine	
General	Overall length (mm)	4700	
	Overall width (mm)	1890	
	Overall height (mm)	1710 (1720: including roof rack) (1727: combination antenna)	
	Gross vehicle weight (kg)	A/T	4WD: 2170, 2WD: 2080
		M/T	2WD: 2050
	Curb vehicle weight (kg)	A/T	4WD: 1718, 2WD: 1628
		M/T	2WD: 1598
	Fuel	Gasoline	
Fuel tank capacity (ℓ)	50 (EU), 47 (GEN)		
Engine	Engine	G15DTF	
	Number of cylinders/Compression ratio	4 / 9.5:1	
	Total displacement (cc)	1497	
	Camshaft arrangement	DOHC	
	Max. power	120 kW / 5000~5500 rpm	
	Max. torque	280 Nm / 1500~4000 rpm	
	Idle speed	700 ± 50 rpm	
	Cooling system	Water-cooled / forced circulation	
	Coolant capacity (ℓ)	7.0	
	Lubrication type	Gear pump, forced circulation	
	Max. oil capacity (ℓ) (when shipping)	4.5	
Turbocharger and cooling type	Turbocharger, water-cooled		

\* ( ) Options, vehicle weights and gross weights are based on the maximum values and they depend on vehicle options and specifications.

## SPECIFICATIONS (II)

\* ( ): Optional

Descriptions		Gasoline 1.5 Engine	
<b>Manual Transaxle</b>	Operating type	Floor change type	
	Gear ratio	1st	3.538
		2nd	1.913
		3rd	1.152
		4th	0.829
		5th	0.689
		6th	0.587
Reverse	3.000		
<b>Automatic Transaxle</b>	Model	Electronic 6-speed	
	Operating type	Floor change type	
	Gear ratio	1st	4.044
		2nd	2.371
		3rd	1.556
		4th	1.159
		5th	0.852
6th		0.672	
Reverse	3.193		
<b>Transfer Case</b>	Model	AWD	
	Type	On demand type	
<b>Clutch (M/T)</b>	Operating type	Hydraulic (CSC) type	
	Disc type	Dry single diaphragm type	

## SPECIFICATIONS (III)

\* ( ): Optional

Descriptions			Gasoline 1.5 Engine
Power Steering	Type		Rack and pinion (EPS)
	Steering angle	Inner	31.82
		Outer	37.72
Rear Axle	Drive shaft type	Independent suspension	Ball joint type
	Axle housing type		IRDA type
Brake	Master cylinder type		Tandem type
	Booster type		Vacuum assisted booster type
	Brake type	Front wheel	Disc
		Rear wheel	Disc
	Parking brake		EPB
Suspension	Front suspension		Macpherson + Coil spring
	Rear suspension		Multi link + Coil spring
Air Conditioner	Refrigerant (capacity)	Type A	R-1234yf (530 ± 30g)
		Type B	R-134a (570 ± 30g)
Electrical	Battery type / Capacity (V-AH)	ISG	AGM / 12 - 70
		NON-ISG	MF / 12 - 60
	Starter capacity (V-KW)	ISG	12 - 1.4
		NON-ISG	12 - 0.9
Alternator capacity (V-A)		14V - 130A	

1

# Precautions for the modification of the vehicle and structural alteration



## Warning

Unauthorized vehicle modification, structural alteration and installation of a component may cause car trouble or a fatal accident. Warranty repair will not be provided in case of product malfunction.

- The vehicle you purchased is made of a lot of precision parts passed through a large numbers of researches and tests, and these parts are linked and operate systematically.
- Modifying or changing any part arbitrarily or installing an unauthorized device may cause car trouble and affect the vehicle's performance, durability, and safety. It may lead to a fatal accident.
- Also, warranty repair will not be provided for a modified part as well as a problem that occurred due to the modification, even during the warranty period.

Do not install a separate accessory or auxiliary device to the vehicle operation device arbitrarily.

- Extending the gear shift lever or installing accelerator pedal or brake pedal pads available in the market arbitrarily may cause an operation mistake due to a change in the operating force of the vehicle. In such case, vehicle damage as well as a serious fatal accident may occur.

Do not modify the engine, driving, and exhaust systems.

- Do not adjust the preset value in the fuel supply system, intake, exhaust, and electric systems arbitrarily, or replace with or add a non-standard part in order to increase the engine output or adjust the exhaust sound. Doing so may cause a serious problem with the vehicle's durability. It is illegal.
- In particular, the modification to an LPG vehicle may adversely affect the vehicle's performance and durability. The engine system as well as the transmission and the wheel alignment are excluded from the warranty.

Do not modify the audio system or install additional electronic devices such as wireless communication equipment, rear view camera, TV, and remote starting devices.

- The electrical system of this vehicle consists of electric wires and fuses for installing standard electronic devices.
- Connecting a number of electric wires to the existing wire for installing various additional electronics may cause overloading, resulting in damage to electronic devices and a risk of fire.
- In addition, drilling for installing an antenna may cause the vehicle to rust.

Do not install non-standard tires or wheel-related parts.

- If you install wider or larger tires than the vehicle specifications, the tires and adjacent parts may come into contact with each other and result in wear and damage to the power train system when you operate the steering wheel or drive on an unpaved road.
- In addition, the degradation of driving performance may occur due to an increase in the fuel consumption and braking distance, vibration of the vehicle body, and degraded handling of the steering wheel, and an impact may occur when shifting with the automatic transmission.
- Moreover, it may affect the speedometer and odometer, displaying an incorrect driving speed or a driving distance longer than the actual driving distance.
- If you install a wheel dust cover in order to improve the appearance of the tires, friction heat generated during braking is not released smoothly, causing the fade or vapor lock phenomenon. This may lead to the degradation of braking performance and cause a serious problem.



Do not install a sunroof available in the market or replace with colored glasses arbitrarily.

- If you cut the roof of the vehicle and install a sunroof, rust or water leaks may occur in the cut part.
- Installing colored glasses to improve the appearance and block UV rays after the vehicle is shipped may cause water leaks. Do not install such glasses.

Do not modify the floor inside of the vehicle arbitrarily.

- Do not install an auxiliary article such as floor coverings on the floor inside the vehicle to enhance the cushioning or convenience for cleaning. Doing so may damage the operating device of various electronic systems and electrical wires, and hinder the function of the seat rail that moves the seat forward and backward.
- Also, the locking system to fix the position of the seats may not operate properly. In such case, the seats may move forward or backward, causing an accident, when driving on a downhill road or an uphill road.

Do not replace the seat with a new one with a different function, or install a separate seat cover.

- There are various types of seats according to the function and role even for the same vehicle type and electric wiring has been applied accordingly.
- Do not bring and over-use or modify an adjacent electrical wire in order to replace a seat with a new one with different functions. In such case, it may damage electronic devices and create a risk of fire due to overloading.
- Replacing a seat cover incorrectly may damage electrical devices due to a short circuit or disconnection, or cause poor ventilation, fire and abnormal noise.

Do not install a bumper guide or a guide bar available in the market.

- If you install a bumper guide or a guide bar arbitrarily, problems such as difficulty in parking and stopping due to an increase in the total vehicle length, the waste of fuel due to an increase in the vehicle weight, and the occurrence of rust on the installation holes may occur. In addition, more serious injury may occur in the event of a collision accident due to the absence of a shock absorber in the bumper guide.

Do not attach a functional product that may decrease the driving resistance such as stickers, molding, air dam, or windproofing products.

- Adhesives of the stickers may damage the coated surface of the vehicle. When drilling is carried out on the vehicle in order to attach molding and other functional parts, the drilled area may rust or abnormal noises may occur while driving.
- Especially if such parts are not attached firmly, such parts may fall off while driving, causing damage to the vehicle as well as a fatal accident.

# Checking before driving

## Daily inspection



- Check the vehicle once a day before driving.
- Check the engine coolant, engine oil, brake fluid, washer fluid, and belts for abnormality.
- Check for leaks from the battery and the radiator.
- Check the bottom of the vehicle to see if there is an oil or liquid leak.
- Clean the front and rear windshields, rear glasses, side mirrors and room mirror.
- Check the operating status of the various lamps.
- Make sure that there are no obstacles that may hinder the driving around of the vehicle.

## Checking engine room

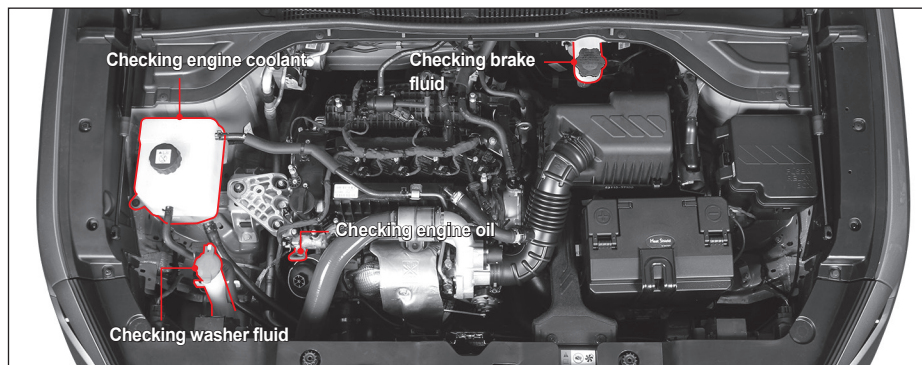

### Checking engine coolant



- Check the engine coolant after cooling the engine properly on level ground.
- Check if the coolant level is between the "MAX" mark and the "MIN" mark on the surface of the coolant reservoir. If the level is near or below the "MIN" mark, add coolant.

### Checking engine oil



- Check the engine oil after stopping the engine on level ground and waiting for more than 5 minutes.
- Check if the oil level is between the "MAX" mark and the "MIN" mark on the oil level gauge. If the level is near or below the "MIN" mark, add oil.

## Checking brake fluid (clutch fluid)



Check if the brake fluid (clutch fluid) level is between the "MAX" mark and the "MIN" mark. If the level is near or below the "MIN" mark, add brake fluid (clutch fluid).

## Checking washer fluid

Check the level of washer fluid on the washer fluid tank and add as needed.



### Caution

- If the level of engine coolant and various oils drops below the "MIN" mark, have your vehicle checked by KG Mobility Authorized Service Center.

## Checking belts

Start the engine and see if there is any abnormal noise.

Have the belts checked by our service center according to the periodic inspection and replacement interval table.

## Checking tires



### Warning

- **Maintain the tire pressure in a proper condition. Driving the vehicle at a high speed with low tire pressure may cause the tires to burst due to the standing wave effect, resulting in a risk such as a rollover.**
- **Check to see if the wheel nuts (bolts) are tightened. Improperly tightened wheel nuts (bolts) can cause an accident.**
- **Using wheel and tire other than the specified sizes could cause unusual handling characteristics and poor vehicle control, resulting in a serious accident.**
- **The use of tire sizes other than the specified sizes may cause abnormal operation of the steering wheel, increased fuel consumption, increase braking distance, vibration, improper operation of ABS/ESC, or uneven tire wear. It may also damage to the powertrain of the vehicle.**
- **Use only the same tires from same tire manufacturer for all the wheels. Otherwise, the powertrain may be damaged.**

- Always check the tread and side of the tires to see if there is a sign of wear, cracks, or damage.
- Check the conditions and pressure of the temporary (spare) tire as needed and always keep it available. The temporary tire should be replaced with a regular tire as soon as possible.
- Check the conditions of the emergency puncture service kit. The air compressor and sealant canister should be available at any time.
- Check the tire inflation and wear everyday and replace if necessary.



### What is the standing wave phenomenon?

The standing wave phenomenon is the occurrence of a wave-shaped wrinkle on a tire with insufficient inflation pressure during high speed driving.

During driving, a tire that has normal inflation pressure repeats compression and restoration, but when a tire with insufficient inflation pressure rolls on the road with high speed, the tire will be compressed significantly and it comes into contact with the road surface again before it is fully restored. If such a situation occurs repeatedly, the standing wave phenomenon will appear.

If the standing wave phenomenon persists, a significant amount of heat is generated on the tire and the tire will be blown out in the end.

## Checking the instrument cluster

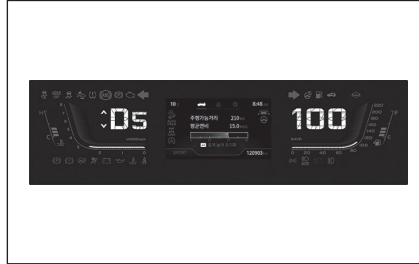

Check if all the indicators and warning lamps are displayed correctly on the instrument cluster with the ignition switch in ON position.

Also, check if all gauges (fuel gauge, vehicle speed gauge, engine RPM gauge, etc.) are operating properly.

## Checking the parking brake

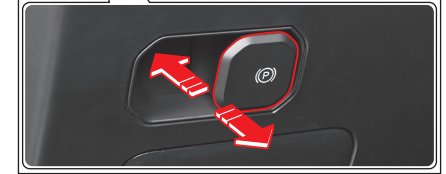

Operate the EPB (Electric Parking Brake) switch and check the operating sound and operation status.

If the parking brake is not applied, have the vehicle checked and repaired by a near-by KG Mobility Authorized Service Center.

## Checking the pedals

Check the operation status of the brake pedal, clutch pedal and the accelerator pedal.

If the operation status of the pedal is abnormal in comparison to its normal status, have it checked and repaired by KG Mobility Authorized Service Center.

## Cleaning up near the driver's seat

Keep the space near the driver's seat clean all the time. Never leave any object that hinders driving.

Always clean up the space near the driver's seat before driving.



### Warning

- **An empty bottle or an article below the pedal hinders the pedal operation and may cause an accident.**
- **If the floor mat is not fixed or is too thick, it may hinder the pedal operation and cause an accident.**

## Advisable driving position



Maintain an advisable position for safe and comfortable driving.

- Sit upright on the driver seat with the hip against the seat cushion.
- Adjust the position and height of driver seat in a way that the brake pedal (clutch pedal) can be depressed to the end comfortably.
- With your back against the seat back, adjust the position and height of the seat back and steering wheel so that you can rest your wrists on the top of the steering wheel.
- Adjust the height of the headrest in a way that the center of the headrest is aligned with the driver's eye level.



### Warning

- **Do not wear shoes such as slippers or high heels that may hinder driving. Such shoes may hinder the accelerator pedal or brake pedal operation and cause an accident.**

## Adjusting the seat, headrest, steering wheel, and mirrors

- Adjust the seat, headrest, steering wheel, and mirrors before driving the vehicle.
- If your steering wheel is adjustable, adjust it to an appropriate height and angle that fits your body and drive the vehicle.
- Adjust the rear glasses, side mirrors and room mirror to an angle that you can see the rear view well.



### Warning

- **If an additional adjustment is necessary while driving, make sure to stop the vehicle at a safe place and make the adjustments. Adjusting while driving may hinder driving, causing an accident.**

## Wearing the seat belt correctly



- Make sure that all occupants inside the vehicle wear a seat belt.
- Wear the seat belt with your body closely against the seat cushion.
- A child who cannot wear a seat belt should be seated in the rear seat using child restraints.
- For a vehicle where an adjustable top shoulder strap fixing device is provided, wear the seat belt by adjusting the shoulder strap control device to your body type.

### Warning

- Do not wear the seat belt under the arm.



- Each seat belt is for one person. Two or more persons should not wear one seat belt together.



- Do not lock the seat belt with a clip or a clamp.



- Insert the seat belt latch only to the relevant buckle.



## Danger

### No drugged, drunk, distracted and drowsy (4D) driving



- Avoid drugged driving. It is an illegal act that may be more dangerous than drunk driving depending on the type and dosage of a drug.
- Avoid drunk driving. Judgment is impaired under the influence of alcohol, making safe driving impossible. It is also an illegal offense that puts the life of occupants in other vehicles in danger.

- Avoid distracted driving. Using a mobile phone or the navigation system, watching DMB, or eating while driving may decrease your concentration, making a risk of an accident higher. In particular, using a mobile phone or watching DMB while driving is an illegal offense that hinders safe driving. When it is inevitable, stop or park the vehicle in a safe place and use the relevant device.
- Avoid drowsy driving. Driving for a long period of time without taking a rest will lead to drowsy driving that may cause an accident. Take a rest at least every 2 hours for safety.

## Warning

### Cautions for air bag

- The air bag system is an auxiliary safety device. Wearing the seat belt properly can minimize injury.
- Do not apply impact to the air bag by hand or with other articles. Doing so may cause the air bag to deploy.
- Do not place any object on, or attach a sticker or other accessories to the air bag inflation location where the air bag is installed. You may be injured by those objects during deployment.

- A passenger who is smaller than 140 cm should sit in the rear seat. Otherwise, the passenger may get injured during deployment.
- A safety device for infants and children should be installed on the rear 1st row. Installing it on the front seat may cause a serious injury or death if the air bag is deployed.
- A pet should be restrained in the rear seat using a dedicated safety device. A pet in the front seat may get injured if the air bag is deployed.
- When the air bag is deployed, the relevant components may be hot.
- A deployed air bag cannot be used again. Please replace it.
- The air bag system should be checked or replaced after 10 years from its installation even if the system has no abnormality. The air bag system should be checked or replaced by a professional technician in KG Mobility Authorized Service Center.
- Do not modify any part of the air bag system arbitrarily. Do not attach any other electrical device to the air bag system.

 Warning

### Precautions for infants, children, old people, or pregnant women



- Never leave an infant, a small child or an old person unattended in the vehicle. They may touch a device inside the vehicle, resulting in an accident. When the doors are locked and the windows are closed during summer, the temperature inside the vehicle will increase, resulting in suffocation.
- Do not allow children to use the ignition key, various switches or buttons, and additional devices without permission. Failure to do so may cause car trouble or even an accident. Their body may get caught in the door, window, or sunroof, and receive injury.
- Do not let an infant, a child or an old person sit in the front seat. The impact from the air bag expansion may cause serious injury or death. An infant or a small child should be restrained with a seat belt or protective gear in the rear seat attended by an adult.

 Warning

### An infant or a small child must be seated in the rear seat with protective gear



- An infant or a small child should be seated in the rear seat with an adult.
- An infant or a small child should be restrained with a seat belt or proper protective gear. Failure to do so may cause serious injury or death in the event of sudden braking or a collision accident.
- Apply the child protection lock system to the rear doors so that children in the rear seats cannot open the rear doors.  
 Refer to "Child safety door lock" (p.3-5)

 Warning

### No sleeping in a sealed vehicle



- Never sleep in a parked car with all the windows closed. In particular, if you sleep with the air conditioner or heater turned on, you can suffocate to death due to a lack of oxygen.
- If you sleep in a sealed space with the engine running, the exhaust gas may flow in, putting you at risk of suffocation.
- While sleeping, you may accidentally touch the gear shift lever or accelerator pedal and cause an accident.
- If you step on the accelerator pedal continuously while sleeping, the engine and the exhaust system may be overheated, causing a fire.



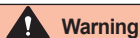

Warning

### Do not drive with the doors or tailgate open



- Do not drive with the doors open. An occupant may fall out of the vehicle and suffer a serious injury.
- If you accidentally operate the door lever while driving and the door is open, it may cause a risk of a serious accident. In particular, do not allow a small child to touch the door lever while driving.
- Avoid driving the vehicle with the tailgate open. Exhaust gas may flow indoors, resulting in gas poisoning.
- If you drive the vehicle with the tailgate open, an article from the inside of the vehicle may fall out, causing an accident.



Warning

### Do not hold a part of your body out of the window or sunroof



- While driving or stopping, do not hold a part of your body such as a hand or head out of the window or sunroof. You may get injured by a passing vehicle or an obstacle.
- In particular, do not allow a child or a pet to hold their hand or head out of the window.



Warning

### Be careful not to have a part of your body caught when using the power window



- Use the power window only after checking that all passengers are safe.
- Before closing the window, check if a part of a passenger's body such as a hand or head is held out of the window and notify them that you will close the window.
- If a small child is seated in the rear seat, press the window lock switch to make the rear window switches inoperative.  
 Refer to "Rear seat window lock function" (p.3-20)

 **Warning**

### Check for any vehicles or persons passing by when getting out



- When you get out, make sure to check the rear and the front of the vehicle to see if there is any vehicle or person passing by. In particular, opening the door without checking a vehicle or a motor cycle approaching from the rear may cause damage to the vehicle as well as injury.
- Warn other passengers to check around before opening the door.

 **Warning**

### Safe parking and stopping

- Never leave an infant or a child unattended in the vehicle with the doors and the windows locked after parking or stopping the vehicle. The temperature inside the vehicle may rise, resulting in suffocation or an accident.
- Always apply the parking brake while parking or stopping. Even a flat area may have a slope. Place the gear shift lever in the P (parking) position and always apply the parking brake.
- Do not stop or park on a steep road. The brake system may be released, causing the vehicle to move.
- When you park on a hillside road, make sure to apply the parking brake and place blocks under the wheels or adjust the wheels to face the wall.
- At this time, place the shift lever in the P (park) position for automatic transmission vehicles and in the 1st gear (uphill) or R (downhill) position for manual transmission vehicles.
- If the vehicle with an automatic transmission, do not use the P (park) position as an alternative to the parking brake, make sure the parking brake is firmly applied during parking.
- Do not park or stop at a place with flammable materials. The heated exhaust pipe may cause a fire.

- If the rear side of the vehicle is too close to a wall, warming up the vehicle for a long period of time, or idling the engine at a high speed may cause the wall to be discolored, or cause a fire due to the heat from the exhaust gas. Keep a proper distance.
- If possible, do not park the vehicle in a humid area or a poorly ventilated area.

 **Warning**

### Warming up the engine correctly

- Drive after warming up the engine properly. Driving immediately after starting the engine may decrease the engine's life expectancy.
- Warm up the engine just until the coolant temperature gauge begins to move. The warming up period may vary according to the outside temperature.
- Do not depress the accelerator pedal and increase the engine RPM rapidly during the warming up period. Doing so may damage the engine.
- Do not warm up the engine excessively. Doing so increases the fuel consumption and air pollution.
- Do not warm up the engine in a sealed space. Exhaust gas may flow indoors, resulting in gas poisoning.



### Warning

#### Do not stop the engine while driving

- Do not stop the engine while driving. Doing so may make the steering wheel heavier and lower the brake performance, becoming very dangerous.

However, if you need to stop the engine in an emergency situation while driving due to an accident or a vehicle damage, refer to the following.

☞ Refer to “Stopping the engine while driving (in the event of emergency)” (p.4-4)

#### No sudden starting, acceleration or braking

- Do not start, accelerate, or brake the vehicle suddenly. Doing so may increase the fuel consumption or cause an accident.
- Accelerate or decelerate the vehicle gently.

#### Driving on unpaved and mountain roads

- Before driving, check road conditions in advance to see if the road ends suddenly, or if there is enough space to make a U-turn for emergencies.
- In sandy or dry roads with much soil, the vehicle may slide easily. Keep your speed low and steady.
- Drive carefully on mountain roads, since the outer part of the road has a danger of collapsing.
- When driving downhill, downshift, and drive slowly by applying the engine brake.



### Warning

#### In high mountain area

- The operation stability of diesel engine is not guaranteed in high mountainous area over 2,500 meters. The short trip such as passing through tunnel in this area is acceptable. However, do not keep driving there for a long time. If you drive your vehicle in very high altitude for long time, the engine could be damaged. The engine power, climbing ability and emission are subject to the altitude.

#### Driving on a snowy or icy road

- If possible, drive slowly.
- Since the braking distance is longer than usual, maintain a proper distance from the car ahead.
- Accelerating or braking suddenly may cause your vehicle to slide, resulting in an accident.
- When you drive on a frozen or slippery road, use the engine brake after decelerating properly. Applying the engine brake suddenly may cause your vehicle to slide, resulting in an accident.
- Apply your brakes after decelerating the vehicle speed properly using the engine brake.
- Use snow tires for safer driving when driving on a snowy or icy roads.



### Warning

#### Driving on a sandy or muddy road

- Keep your speed as low and steady as possible.
- Accelerating or stopping suddenly while driving may cause the vehicle to be caught in the sand or mud.
- If the vehicle is caught in the sand or mud, place a stone or a wooden plate below the wheels and drive off from the sand or mud. Or, depress the accelerator pedal slowly and drive off using inertia by forwarding and reversing repeatedly.
- If you depress the accelerator pedal excessively to drive off from the sand or mud, the tires may slip, causing damage to the transmission and relevant driving systems. If possible, have your vehicle towed by another vehicle.



### Warning

#### Driving on a hillside road and downhill road

- Downshift in accordance with the road conditions.
- If you apply the engine brake suddenly while driving on a hillside road or a downhill road, the engine may get damaged. Reduce the vehicle speed and downshift.
- Use the brake pedal and the engine brake together on a long downhill road. Applying the brake pedal continuously on a long downhill road may overheat the braking system, lowering the braking performance and resulting in an accident.



### Warning

#### Driving on a road with a pool of water or a river

- Avoid crossing a road with a pool of water or a river if possible. If water gets into the engine or the electric systems, it may cause serious damage to your vehicle.
- If you need to cross a road with a pool of water or a river unavoidably, select a shallower part where the exhaust pipe will not be submerged under water and cross slowly at a constant speed.
- Before crossing a river, get out of the vehicle and check the bottom of the river. Do not cross through a place where the bottom is sandy or covered with big rocks.
- If several vehicles cross the river together, the path where the vehicle ahead has crossed may have caved in. Cross through a different path if possible.

#### Cautions for crossing

- If the engine stops while crossing a road with a pool of water or a river, do not restart, and have your vehicle towed.
- Take particular caution not to allow water to enter into the engine through the air cleaner.
- Never change gears while crossing a road with a pool of water or a river.

#### Checking the vehicle after crossing

- If water gets into brake-related equipment, the brake performance will be lowered. After crossing a road with a pool of water or a river, drive slowly and depress the brake pedal slightly several times. Drive normally after drying the brake discs with the frictional heat and checking the braking performance.
- Check the parts at the bottom of the vehicle where oil and fluid are injected. If you discover any problems, have your vehicle checked immediately.
- Check the lamps and other electrical devices and replace them if necessary.
- Check for any damage on the vehicle body or at the bottom of the vehicle. If you discover any problems, have your vehicle checked immediately.
- If your vehicle is heavily soiled, wash your vehicle to protect the vehicle body.



### Warning

#### Do not use a cellular phone or watch DMB while driving

- Using your cellular phone or watching DMB while driving will distract yourself and may cause an accident. If necessary, pull over your vehicle safely to use your cellular phone.



### Warning

#### Driving on the expressway

- Before driving, check the weather information in advance, and check the fuel level, brake system, cooling system, level of tire wear and pressure, and maintain the vehicle thoroughly.
- Drive slowly for 2km after starting if possible.
- Always observe the speed limit and do not drive too fast.
- Keep a proper safe distance from the vehicle ahead.
- In case of bad weather, maintain more than twice the safe distance from the vehicle ahead than usual and reduce the speed by more than a half.
- Do not load the vehicle with unnecessary articles.
- Check and maintain the vehicle periodically to maintain the best vehicle condition.

#### Crossing an intersection or railroad crossing

- When you cross an intersection or railroad crossing, stop first, check for safety, and then cross promptly using a lower gear, without shifting if possible.
- If the engine stops in the middle of an intersection or railroad crossing, move the vehicle to a safe place promptly. If necessary, ask people around for help.



### Warning

#### No sudden maneuvering of the steering wheel

- If you maneuver the steering wheel suddenly, the driving condition of the vehicle may become unstable, causing the risk of an accident.

#### Do not warm up the engine or check the vehicle in a sealed space

- Do not warm up the engine or check the vehicle in an airtight or badly ventilated space. The exhaust gas from the vehicle may cause gas poisoning.

#### Use of the engine brake

- When driving on a long downhill road, use the engine brake and the foot brake at the same time. When you downshift according to the driving conditions, the engine brake will operate.
- Using the foot brake excessively may cause the fade or vapor lock phenomenon due to overheating of the brake system, lowering the braking performance.

#### What is the fade phenomenon?

The fade phenomenon is the reduction of braking force due to a decrease in the friction force caused by a temperature increase in the friction surface of brake when the brake is applied excessively on a long downhill road.

#### What is the vapor lock phenomenon?

The vapor lock phenomenon is the condition that when the brake is applied excessively on a downhill road, bubbles form in the brake fluid in the wheel cylinder or brake pipe of the hydraulic brake so that proper hydraulic pressure cannot be transferred, causing the brake system not to operate properly even if the pedal is depressed.



### Warning

#### Cautions for attaching accessories

- Do not attach accessories or unnecessary articles to the vehicle windows. They may interfere with your driving, and if attached accessories act as a lens (magnifying glass), a fire or an unexpected accident may occur.

#### Special cautions when checking the coolant

- Never open the engine coolant reservoir cap when the engine is hot. Doing so may cause hot steam or coolant to erupt, causing burns on your body parts including the hands or face.

#### Do not load hazardous materials

- Do not store any flammable materials such as gasoline, butane gas, or a disposable gas lighter, or explosive materials inside the vehicle. If the indoor temperature rises, the container may burst, causing a fire.



### Warning



Do not remove the coolant reservoir cap when the engine and the radiator are hot. The cooling system may spray hot coolant if the cap is removed, causing serious injuries.



### Caution

#### Cautions for vehicle ventilation

- For a new vehicle purchased within 1 year, harmful volatile organic compounds (VOC) to human body may be emitted in the cabin. In particular, riding a vehicle exposed to direct sunlight for a long period of time or without proper ventilation may cause headache, dizziness or nausea.
- Operate the fresh air inflow mode or open the windows periodically to ventilate air inside the vehicle for the health of passengers and a pleasant vehicle environment.



### Caution

#### System protection function (delayed accelerator pedal response)

- Do not depress the brake pedal while driving with the accelerator pedal depressed. Doing so may affect the vehicle driving system and the response from the accelerator pedal may be delayed.
- This symptom is a safety function to protect the vehicle system. This symptom will disappear if you depress and release the accelerator pedal once with the brake pedal not depressed.

#### Placement of extinguisher

- An extinguisher is an essential item for early extinguishing when a fire occurs. It is recommended to purchase it from a fire-fighting appliance store and place it in the vehicle.

## KG Mobility Authorized Service Center and maintenance partners

KG Mobility Authorized Service Center or maintenance partners for checking and repairing the vehicle. If you use other service centers or maintenance shops, warranty repair will not be available and warranty will not be provided for any consequent problems.

## Cautions for the depletion of battery when connecting uninterruptible power supply to the black box system

If the vehicle is not operated for a long period of time with the uninterruptible power supply connected to the black box system, the vehicle battery may be depleted.

Turn off the black box system if you will not drive the vehicle for a long period of time.

## Long-term parking mode

This mode is for preventing vehicle battery discharge. Set it on the instrument cluster and use it if necessary.

During setup, smart key search is stopped to minimize power and some functions are limited.

## Breaking in a new vehicle correctly

Break-in is not required for a new vehicle. However, the driving condition for the first 1,000 km significantly affects the life and performance of the vehicle. Pay attention to the following when driving during this period.

- Allow the engine to reach normal operating temperature before driving.
- Do not speed, accelerate, brake suddenly, or idle the engine excessively.
- Shift properly according to driving speed.
- Do not overload the engine while driving a sloping road.
- Do not tow a trailer during the first 1,000 km.
- During the first 1,000 km of towing a trailer, do not drive at a speed over 80 km/h or with full acceleration. Doing so may damage the engine or other components due to overload.
- Check the level of engine oil frequently until the first 5,000 km of operation and add oil if necessary.

## Using genuine parts

Always use genuine parts for maintaining safety and the best performance of your vehicle. Warranty repair will not be provided for car trouble caused by using a non-genuine part.

You can verify a genuine part by its hologram and sticker with the product number.



- **The warranty does not cover problems caused by using non-KG Mobility genuine parts.**
- **You can distinguish an authentic KG Mobility genuine part by its hologram.**

## Vehicle washing

After driving on a coastal road (salty road), a road where calcium chloride was spread, an area with excessive smoke or coal tar, or a muddy or dusty area, or when the vehicle is stained with tree sap or insects' or birds' droppings, wash the vehicle immediately since corrosion may occur on the vehicle body.

- Avoid direct sunlight and wash the vehicle in the shade. If your vehicle has been parked under direct sunlight, let it cool properly before washing.
- Dust off the vehicle with cold water.
- Mix cold water with detergent in a bucket and wipe the vehicle from top to bottom using a soft brush, sponge, or cloth.
- Wash off any foreign materials on the vehicle body without damaging the painted surface.
- Any scratched or damaged painted surface causes corrosion, so repair them with paint for repair.
- Remove moisture using a dry and soft cloth.
- After washing, drive the vehicle normally after driving it slowly, and checking the operating status of the brakes.



### Caution

- **Be careful not to damage the air spoiler when cleaning the vehicle in an automatic car wash.**
- **When you wash the bottom or exhaust pipe of the vehicle with water (including high pressure washing), be careful not to damage the sensors or connectors connected to the exhaust pipe and prevent water intrusion. Our warranty will not be provided for any consequent failure.**
- **Avoid washing with water when the brake discs are hot. Hot brake discs may be deformed or damaged if it comes into contact with water.**
- **If possible, avoid high pressure washing for maintaining and managing the vehicle performance.**
- **High pressure washing may damage the components and sensors installed on the exterior of the vehicle and the painted surface of the panels. In particular, be careful not to get water into the electrical devices and sensors at the bottom of the vehicle.**
- **When you use high pressure washing unavoidably, maintain a proper distance between the high pressure water nozzle and the vehicle. If the distance is too close, the sensors on the bumper may malfunction or the painted surface of the panels may be damaged due to the high water pressure.**

- **Do not use abrasive wax and strong cleaning materials such as steel wool which will scratch the vehicle body and bumper.**
- **Do not wash the engine compartment using liquid materials such as water or wax. If liquid materials get into the inside of the engine through the electrical devices (sensors) or air ducts located in the engine compartment, various electrical devices may malfunction or the vehicle's operation may not be possible.**





## Washing the bumper

- Wipe off foreign materials using a soft sponge.
- If the bumper is contaminated by engine oil or any lubricants, wash it off using soapy water.



### Caution

- **Do not use abrasive wax or a brush to wipe the bumper or the vehicle body. Doing so may damage the bumper or the surface of the vehicle body (painted surface).**

## Washing wheels

Clean the wheels after driving on a salty road to prevent the wheels from being corroded.



### Caution

- **Do not use abrasive cleaners, polishes, solvents, wire brushes, and high speed washing brushes since they may damage the wheel surface.**
- **Using acid or alkaline detergents could damage the wheel surface (painted surface), so use neutral detergents for cleaning the wheels.**
- **Using strong cleaners may discolor the wheel surface. Make sure to use natural cleaners. A discolored wheel due to carelessness is not subject to free warranty repair.**

## Cautions for polishing the vehicle

- Before waxing, remove dust or moisture from the vehicle.
- Apply a small amount of wax on a soft cloth, apply it to the whole vehicle body evenly, and scrub a wide area in the same direction to polish.
- After waxing, remove residual wax from the vehicle body completely.



### Caution

- **Do not polish or wash the vehicle body using wax containing abrasives. Doing so may damage the surface of the vehicle body (painted surface).**

## Cleaning and maintaining glass

- Clean the indoor and outdoor sides of glass windows using a glass cleaner and a soft cloth.
- When cleaning the glass windows, be careful not to damage the electric demister element.
- When automatic car washing is used, coating (wax) substance included in the cleaning fluids may adhere to the glass surface and it may not be wiped off easily when it is dried. Spray washer fluid and operate the wipers two or three times to remove coating (wax) substances using the cleaning substances included in the washer fluid.
- Do not wipe the glass surface with a towel stained with oil or wax. Doing so may cause vibrations and abnormal sounds when the wipers are operating and the front and rear windshields may not be cleaned properly when it rains. Also, the reflection of light may occur at night, causing poor visibility and affecting safe driving.

## Cautions for window tinting

- All vehicles from our factory have tinted windshields and rear windows that meet the specified percentage of visible light transmission (VLT). Do not tint the windows of the product. Doing so will lower VLT, becoming subject to legal regulation.
- Tinting the windshield and rear window excessively may reduce front and rear visibility at night or in case of rain, causing an unexpected risk.
- When tinting the windshield and rear window, do not allow working solutions to enter into electrical and electronic devices. Failure to do so may cause a malfunction or failure of electrical and electronic devices.
- If the windshield and rear window are modified or tinted arbitrarily, the electric demister element may be damaged by a knife or a tool or an electrical shock.
- If the windshield and rear window are coated or tinted (metallic tinting film), the Hi-Pass system, rain sensor, and radio may not operate normally.
- Do not tint the front camera sensing part. Otherwise, the relevant system may malfunction.

## Care and cleaning of the interior

- Use a dry towel for normal cleaning.
- For synthetic resin such as plastic, clean it with lukewarm water and soap and wipe off with a wet towel with no soap.
- Wipe using a dry towel to dry.
- Remove dust on the seats and mats using a vacuum cleaner.
- If the mats are heavily stained, spray a cleanser on them and wipe using a cloth.



### Warning

- **To prevent from burning and electric shock, turn off the interior lights before cleaning the vehicle interior.**



### Caution

- **When you use chemicals for cleaning the interior, the color or shape of the interior may change.**
- **Do not use chemical products such as acetone, enamel, and bleach for cleaning the interior.**
- **The Leather Seat Maintenance is necessary on Quarter basis with dedicated Leather Milk or Cream in order to feed the Leather and avoid any cracks on the seats and conserving the original look and comfort of the seat.**

## Seat Belt Care

- Keep belts clean and dry.
- Clean seat belts only with mild soap and lukewarm water.
- Do not bleach or dye belts since this may severely weaken them.

## Cautions for using the vehicle key

- Be careful not to lose your key.
- If your key is lost or stolen, replace the whole key set to prevent the vehicle from theft.
- Do not throw or drop your key. Doing so will damage your key. Do not drop your key in water.
- Use only the same standard battery for the key and be careful not to switch the polarity when inserting the battery.

## Corrosion protection

Your car was designed to resist corrosion. When it was built, special and protective finishes were used on most parts of your car to help maintain a good appearance, strength and reliable operation. Some parts which normally are not visible (such as certain parts located in the engine compartment and the underbody of the vehicle) are such that surface rust will not affect their reliability. Therefore, corrosion protection is not needed or used on these parts.

## Sheet Metal Damage

If your car is damaged and requires body panel repair or replacement, make sure the body repair shop applies proper anticorrosion material to the parts repaired or replaced so that corrosion protection is restored. (Also refer to “Finish Damage” on the next page).

## Foreign Material Deposits

Calcium chloride and other salts, deicing agents, road oil and tar, tree sap, bird droppings, chemicals from industrial chimneys and other foreign materials may damage vehicle finishes if left on painted surface. Prompt washing may not completely remove all of these deposits. Other cleaners may be needed. When using chemical cleaners, be sure they are safe for use on painted surfaces.

## Finish Damage

Any stone chips, fractures or deep scratches in the finish should be repaired promptly. Bare metal will corrode quickly and may develop into a major repair expense. Minor chips and scratches can be repaired with touch-up materials. Larger areas of finish damage can be corrected in your Distributor's body and paint shop.

## Underbody Maintenance

Corrosive materials used for ice and snow removal and dust control can accumulate on the underbody. If these materials are not removed, accelerated corrosion (rust) can occur on underbody parts such as the fuel lines, frame, floor pan, and the exhaust system even though they have been provided with corrosion protection. At least every spring, flush these materials from the underbody with plain water. Take care to clean any area where mud and other debris can accumulate.

Sediment packed in closed areas of the frame should be loosened before being flushed. If desired, your KG Mobility Distributor can do this service for you.



### Caution

- When the engine is washed, fuel, grease or oil residues are washed off. Therefore you should use only a filling station or a KG Mobility Distributor who has oil separator equipment in the car wash bay.
- Used engine oil, brake fluid, transmission fluid, antifreeze, batteries, and tires should be disposed by using the local authorized waste disposal facilities, or have them disposed of by the vendor who is under a statutory obligation to do so when you replace them.
- None of these items should be placed in the household recycling bins or poured into the sewage system.
- Everyone should be concerned about environmental protection.
- Help by doing your share.
- When a strong multi-purpose, acid, or alkaline detergent is used to clean up the surface of the painted body, side mirrors, windshield, plastic moldings or leather, changes, fading of colors or rusting can happen.

- When the windshield is cleaned with an oil-contained or waxed towel, strange sounds and vibrations may occur on the windshield surface when the wipers are operating. Also, decreased visibility, reflection at night, or poor removal of water on the windshield may happen. Do not clean the windshield with an oil-contained or waxed towel.
- An abrasive detergent may damage the painted surface of your vehicle, including the bumper. Do not buff or polish your vehicle with an abrasive detergent.
- An acid or alkaline detergent may damage the painted surface of the aluminum or alloyed wheels.
- When chemical products are used to clean up the interior, the chemical products may change some colors or distort the shape of some interior parts.
- When cleaning up interior parts, do not use chemical products such as acetone, enamel or bleach.

## System safety mode

The protective measures including illumination of engine warning lamp and reduced engine power are taken (engine turned off in worst case) when there is a critical fault in the system or a malfunction in the major electrical or fuel system. This indicates the system entering the safety mode to protect the vehicle's drive system.



### Danger

- **If the safety mode is activated, pull over and stop the vehicle to a safe location immediately and contact your KG Mobility Dealer. Then drive slowly or have the vehicle towed to a KG Mobility Dealer or KG Mobility Authorized Service Center according to the dealer's instruction and have your vehicle checked by a mechanic.**
- **If you continue to drive in this state, normal driving is not maintained due to the fixed engine rpm and engine can stop. But even more importantly, continued driving with this state may damage the drive system.**

## Vehicle Fueling from Drums or Storage Containers

For safety reasons (particularly when using noncommercial fueling systems) fuel containers, pumps and hoses must be properly earthed.

Static electricity build up can occur under certain atmospheric and fuel flow conditions if unearthed hoses, particularly plastic, are fitted to the fuel dispensing pump.

It is therefore recommended that earthed pumps with integrally earthed hoses be used, and that storage containers be properly earthed during all noncommercial fueling operations.

## Fuel recommendation

Commercially available high-quality fuels are suitable. Fuel quality has a decisive influence on the power output, driveability and life of the engine. The additives contained in the fuel play an important role in this connection. You should therefore use only high-quality fuels.

### Gasoline Engine

Fuel with too low an octane number can cause pre-ignition (detonation). KG Mobility can not be held liable for resultant damage.

### Fuel Recommendation

Type	Unleaded gasoline (Octane number 95 or higher)
------	---



### Caution

- **For correct octane rating setting and other use of gasoline (ex. Leaded), consult your KG Mobility Dealer.**



### Caution

**Engine and exhaust system will be damaged.**

- **Do not use leaded fuel to the vehicle for unleaded fuel.**
- **Use the fuel with specified or higher Research Octane Number recommended for your country by KG Mobility. It is not covered by warranty.**

## Do not Use Methanol

Fuel containing methanol (wood alcohol) which is not qualified EN228 and EN590 standards should not be used in your TORRES. This type of fuel can reduce vehicle performance and damage components of the fuel system.

The warranty policy will not cover damage of the fuel system and any performance problems that are caused by the use of methanol or fuel containing methanol.

## Engine check indicator

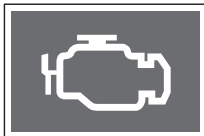

The engine check indicator on the instrument cluster turns on when the fuel system of the engine or main electrical systems are not working properly. At this time, the driving power of the engine may decrease or the engine may turn off.

If it occurs, have your vehicle checked and maintained by our service center.

## Other maintenance

After driving on a calcium chloride (salt) sprayed road, wash the bottom of your vehicle as soon as possible to avoid any rust.

When parking on a snow-covered road, the brake system may begin to have some ice on it. The ice will decrease your vehicle's braking ability. If this happens, drive at a low speed and use the brake frequently to remove the ice. After regaining the braking ability, drive your vehicle at a normal speed.



### Warning

- **When there is ice on the wiper blades, turning on the wiper switch may put an extra burden on the wiper motor and damage it. Avoid using the wipers when ice is on the blades.**
- **When driving on a snow-covered road, a large amount of snow may build up under each wheelhouse. This buildup prevents the steering wheel from moving freely. Therefore, remove the snow buildup frequently.**

## 2. Safety Units

You can check information regarding units that allow you to drive the vehicle safely and how to use such devices.

An explanation is provided for seat belts, a child restraint for an infant or a small child, airbags, anti-theft and warning system.

## Seat belt

The seat belt is the most fundamental safety unit that protects an occupant and prevents or reduces injury when an accident occurs.

If you do not fasten the seat belt or fasten the seat belt incorrectly, the seat belt does not function properly and you may also get injured by the seat belt.



### Warning

- All occupants must fasten their seat belt before driving. Failure to do so may lead to a fatal accident, in case of emergency or when the brake is applied suddenly.
- The air bag can ensure the safety only when the seat belt is fastened correctly. If the air bag inflates when you do not fasten the seat belt or fasten it incorrectly, you may get injured by the inflated air bag.

## Seat belt warning

If the occupants in the driver seat and the front passenger seat do not fasten their seat belts, the warning lamp on the instrument cluster blinks along with a warning buzzer.

The rear seat (left, center and right) reminder illuminates the warning lamp or sounds the buzzer depending on the vehicle conditions and whether the seat is occupied or not.

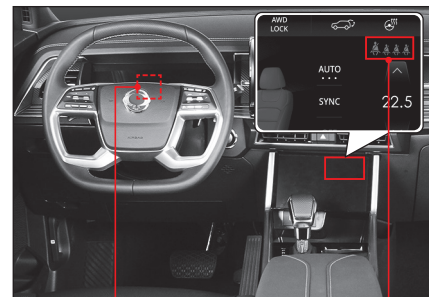

- 1 Warning lamp for driver and front passenger
- 2 Front passenger warning lamp
- 3 Rear (left) seat warning lamp
- 4 Rear (center) seat warning lamp
- 5 Rear (right) seat warning lamp



## Front seat (driver / passenger) belt reminder

- The seat belt reminder warning lamp and buzzer are triggered only when the ignition switch is turned on or the engine is started.
- If you turn the ignition switch on or start the engine with the seat belt not fastened, the warning buzzer sounds and warning lamp flashes for about 6 seconds. At this time, when the seat belt is fastened, the warning buzzer stops and the warning lamp flashes for the rest of the time.
- If you turn the ignition switch on or start the engine with the seat belt fastened, only the warning lamp flashes for about 6 seconds.
- If you fasten and then unfasten the driver seat belt, the warning buzzer sounds while the warning lamp flashes for about 6 seconds. However, for the passenger seat, the warning lamp and buzzer do not work even if the seat belt is fastened and then unfastened.
- When driving the vehicle at a speed of about 10 km/h or higher with the seat belt not fastened, the warning lamp comes on for about 100 seconds and the warning buzzer sounds. After 100 seconds, the warning buzzer stops and only the warning lamp stays on.

## Front seat (passenger) belt reminder

- The seat belt reminder warning lamp and buzzer are triggered only when the ignition switch is turned on or the engine is started and a front passenger is detected.
- The seat belt reminder is issued at the same time by the instrument cluster and the buttonless integrated control panel.
- If you turn the ignition switch on or start the engine with any front passenger not seated, only the warning lamp flashes for about 6 seconds.
- If you turn the ignition switch on or start the engine without fastening the passenger's seat belt while the system detects that the front passenger seat is occupied, the warning buzzer sounds and warning lamp flashes for about 6 seconds. At this time, when the front passenger seat is detected as unoccupied or the front passenger seat belt is fastened, the warning lamp flashes for the rest of the time.
- If the seat belt is not fastened after 6 seconds, the seat belt reminder will activate and the warning lamp will flash. At this time, when the front passenger seat is detected as unoccupied or the front passenger seat belt is fastened, the warning lamp will go out immediately.
- When a front passenger is detected with the ignition switch in the ON position, the seat belt reminder is activated.

## Rear seat (left / center / right) belt reminder\*

- The rear seat belt reminder warning lamp comes on for 70 seconds when the ignition switch is turned on regardless of whether the seats are occupied or not and the warning buzzer does not sound.
- The rear seat occupancy sensor recognizes that the corresponding (left, center and right) seat is occupied when the rear seat belt is fastened and then unfastened with the ignition switch turned on.
- If the seat belt is fastened when the warning lamp comes on for 70 seconds by turning the ignition key on the corresponding warning lamp goes off.
- If the rear seat belt is fastened and then unfastened at a vehicle speed of 10 km/h or less, the corresponding warning lamp stays on until the seat belt is fastened. At this time, the warning buzzer does not sound.
- If the rear seat belt is fastened and then unfastened at a vehicle speed of 10 km/h or higher, the corresponding warning lamp keeps flashing until the seat belt is fastened and the warning buzzer sounds for 70 seconds.
- The rear seat occupancy is reset when: the rear door is open and closed with the vehicle stationary (speed of 0 km/h) and ignition switch turned on.



### Caution

- The passenger seat belt warning operates only when an occupant on the front passenger seat is detected. When the occupant on the front passenger seat is positioned inappropriately or is too small, the occupant may not be detected.
- When an object is placed on the front passenger seat, the occupant detection sensor may operate and the passenger seat belt warning may operate.
- If the warning lamp or the warning buzzer persists after fastening the seat belt, have your vehicle checked and serviced at a KG Mobility Corporation Authorized Service Center.

### Notice

- Seat belt warning may persist until the seat belt is fastened depending on the vehicle condition.
- When the gear shift lever is maintained at the R (reverse) position for 1.5 seconds or longer, the seat belt warning (reminder) does not operate.
- If the vehicle speed falls below about 10 km/h while the seat belt reminder is in operation, the seat belt reminder is deactivated and a seat belt warning is activated.

## Fastening the seat belt

- 1 Sit upright on the seat with the hip against the seat cushion.
- 2 Hold the seat belt latch and pull it slowly in the direction of the buckle.



### Warning

- Wear the seat belt in a way that it is not twisted. If the seat belt is twisted, it cannot distribute the impact at the time of an accident properly.

### Notice

- If the seat belt is locked and does not move, loosen the seat belt a little bit and pull it slowly or strongly. In some cases, you have to pull the seat belt strongly for approximately 2 to 3 seconds to move it.

- 3 With the shoulder belt webbing positioned across the chest and the lap belt webbing positioned across the hips, insert the belt latch into the buckle until it clicks.

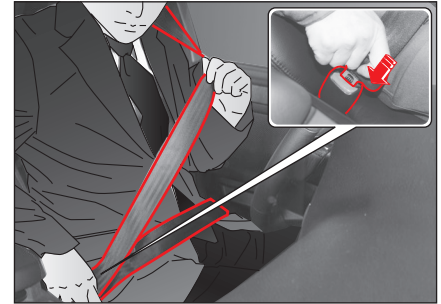

### Warning

- Fasten the seat belt in a way that the shoulder belt webbing is positioned across the chest. If the shoulder belt webbing is positioned across the neck, a serious injury may occur by the belt in the event of an accident.
- Position the lap belt webbing as low as possible across the abdominal area. If the lap belt webbing is positioned across the abdominal area, an impact may happen in the event of an accident, resulting in a serious injury.
- Pull the belt latch to make sure that it is securely locked into the buckle.

- 4 Adjust the height of the shoulder belt webbing using the seat belt height adjuster if needed.
- 5 Adjust the belt webbing on the chest and the hips to not be slack.

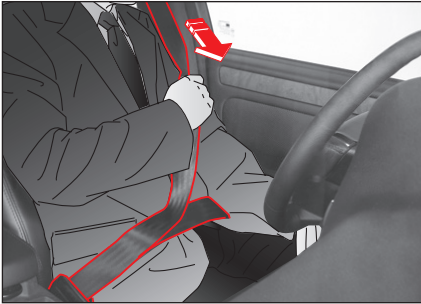

**Warning**

- Do not fasten the seat belt higher than the body or loosely. Doing so may cause the body to slip below the seat belt in the event of a collision accident, resulting in injury.

## Unfastening the seat belt

- 1 To unfasten the seat belt, press the red button on the buckle and separate the belt latch from the buckle.

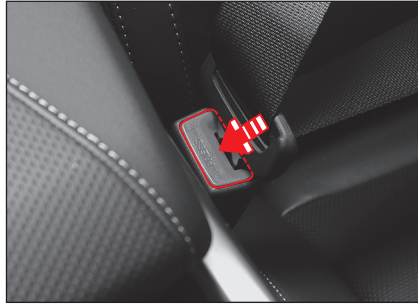

- 2 Hold the belt latch and let the seat belt webbing to be wound slowly.

## Managing the seat belt

### Adjusting the height of the front seat belt

You can adjust the height of the shoulder belt anchorage to prevent the seat belt from being positioned across the neck.

**Warning**

- Adjust the height of the seat belt before driving.

- 1 With the top of the seat belt height adjuster pressed, raise or lower the seat belt holder.



- 2 Release it at the desired position. The seat belt holder is secured.

## Rear seat belt storage

If you do not use the rear seat belts or wish to fold the rear seat back, insert the seat belt into the webbing guide installed on the wall as shown in the figure.



### Caution

- Remove from the webbing guide first if you wish to use the seat belt. Pulling the seat belt with the webbing guide inserted may damage the webbing guide or the seat belt.

## Rear seat buckle storage

If you do not use the rear seat belts, insert the buckle into the buckle storage as shown in the figure.

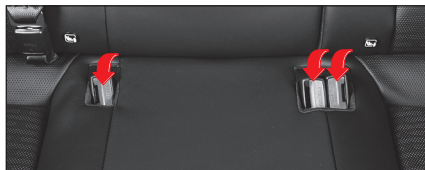

## Rear center seat belt storage

Have the auxiliary latch inserted into the auxiliary buckle always if you do not use the rear center seat belt.

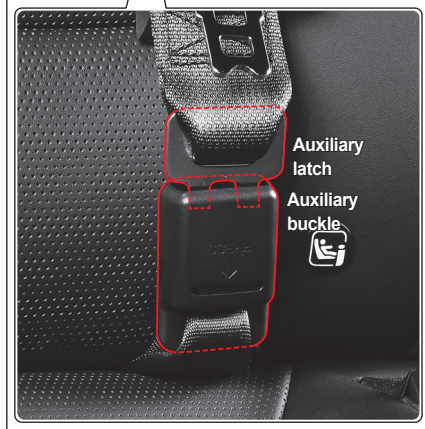

## Rear center seat belt release

- 1 Press the auxiliary buckle hole (1) using the emergency key.



- 2 Hold the auxiliary latch (2) and left the seat belt to be wound slowly.

### Warning

- If the auxiliary latch retracts at high speed, an adjacent occupant may get injured.
- Do not allow a child to pull and release the auxiliary latch repeatedly.

## How to fasten the seat belts (2-point) in rear center seat

- 1 Pull out the latch plate at the bight of the seat.

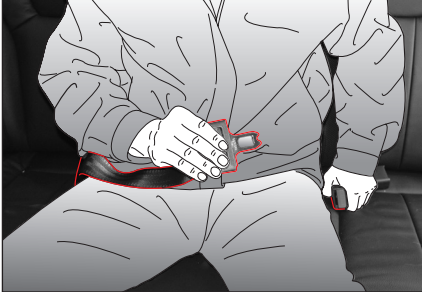

### Warning

- Put the lap belt as low as possible across the hips. Do not put it across waist. In an accident, the belt may apply pressure to your abdomen. This may cause serious internal injuries.

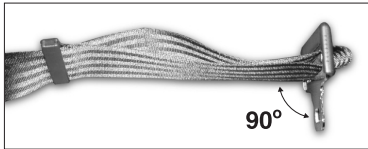

To lengthen, hold the metal latch plate at a right angle to the belt and pull the belt. To shorten, pull the free end of the belt away from the latch plate, then pull the belt clip to take up the slack.

- 2 Insert the metal latch plate into the buckle until it clicks. Position the belt as low as possible across your hips, not across your abdomen.

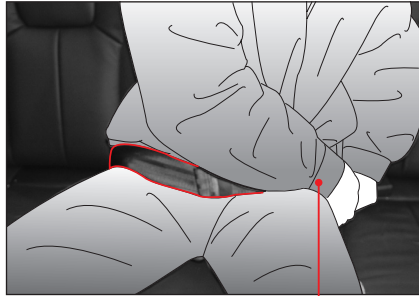

- 3 If the belt is too tight or slack on your hips, readjust the belt.
- 4 To unfasten the seat belt, press the red button on the buckle.

## How to fasten the seat belt (3-point) in rear center seat

- 1 Pull out the latch plate from the retractor. If the seat belt is locked when being pulled out, rewind it completely in the retractor, then pull it out to the desired length.

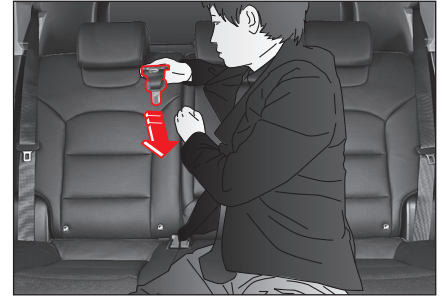

- 2 Insert the latch plate into the right mini buckle until it clicks.

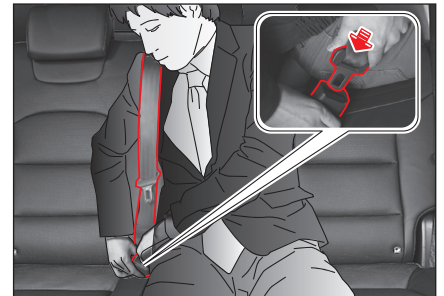

- 3 Position the shoulder belt across the body and the lap belt as low as possible across the hips. Insert the latch plate into the buckle until it clicks.
- 4 Pull the latch plate to make sure it is securely locked. A slack belt will greatly reduce the protection afforded to the wearer.
- 5 To unfasten the seat belt, press the red button on the buckle.

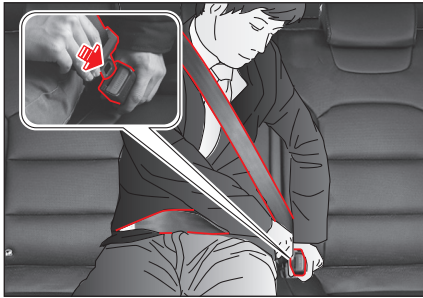

### Warning

- Make sure to fasten the seat belt according to the order as described so that it functions properly.
- To prevent the seat belt from bumping against the rear glass, unfasten the seat belt while holding it.
- This seat belt is designed only for a passenger who sits on the center seat in the rear seat.
- Tug on the seat belt to make sure that the latch plate is securely locked.
- Make sure that the seat belt is not twisted.
- Improper wearing of seat belts increases the chance of injury or death in case of a collision.
- Position the seat belt away from your neck and abdomen.

### Caution

- Stow the seat belt into the console when it is not in use.

## Seat belt pretensioner and load limiter

The seat belt pretensioner and the load limiter are the units that operate at the same time when the driver and front passenger air bags operate, increasing the safety effect of the seat belt and the air bag.

### Pretensioner

The seat belt pretensioner is a protection unit that draws back the seat belt on the occupant's chest and hips instantaneously and secures the occupant to the seat to prevent the occupant from bouncing forward in the event of a strong front collision.

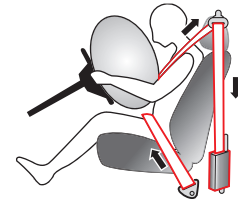

### Danger

- The seat belt pretensioner is designed to operate only once. After it operates, replace the seat belt.

## Load limiter

The seat belt load limiter is a protection unit that releases the seat belt right after a vehicle collision to prevent a secondary injury due to belt force.

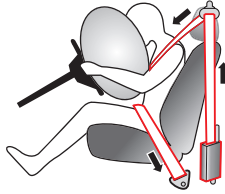

## Fastening the seat belt by a pregnant woman

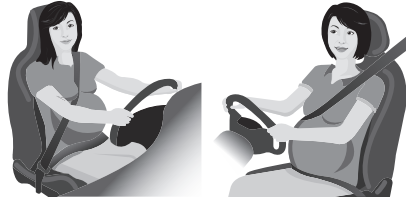

### Warning

- It is dangerous for a pregnant woman to drive, so please avoid it if possible. If it is unavoidable, consult a doctor about the precautions and fastening the seat belt during pregnancy.
- Fasten the seat belt before driving. If an accident occurs without fastening the seat belt, may be dangerous for both the pregnant woman and the fetus.
- When a pregnant woman fastens the seat belt, make sure that the belt is not positioned across her abdomen. If the belt presses her abdomen, in the event of a vehicle collision or when applying a sudden brake, may be dangerous for both the pregnant woman and the fetus.

## Warnings for the seat belt

### Warning

#### Infants, small children, pregnant women or patients

- The child restraint should be used for an infant or a small child. In particular, please note that the three-point seat belt is designed for a person who is taller than 140 cm.
- In the event of a sudden stop or an accident while a pregnant woman or a patient is wearing the seat belt, strong force may apply to the abdomen or other body parts. Make sure to consult a doctor before fastening the seat belt.

#### Position and method to fasten the seat belt

- The seat belt is designed for only one person. Two or more persons should not share one belt.
- If the position of the seats is incorrect, it is impossible to fasten the seat belt correctly. Always adjust the position of the seats to their normal status for driving.
- Fasten the seat belt after keeping the seat upright and leaning the back against the seat backrest with the hip against the seat cushion. If the seat belt is positioned too high or fastened too loose, the body may fall out from the shoulder belt webbing or the lap belt webbing, resulting in a serious injury or death.

- If a strong impact occurs while the seat belt is fastened with the seat backrest reclined too much, the body may fall out below the belt, causing the belt to hang around the neck and result in a serious injury.
- If the seat belt is positioned across the neck, a serious injury may occur by the seat belt when an accident occurs. Make sure to wear the three-point seat belt in a way that the belt webbings are positioned across the chest and the hips.
- Do not pull your arm over the shoulder belt. Doing so prevents the seat belt from effectively blocking the body from bouncing forward in the event of a collision. A head or neck injury may occur accordingly and the impact is applied to the ribs that are weaker than the shoulder bone, causing a serious injury.
- When the shoulder belt webbing is positioned across the abdomen, the body may fall out below the belt or a great impact may be applied to the abdomen, causing a serious injury such as intestinal rupture.
- If the belt latch is inserted into another buckle that is not the relevant buckle, the safety belt may not fit the body correctly so that it cannot protect the body properly.
- In addition, if the lap belt webbing of the two-point seat belt is too loose or the seat belt is fastened incorrectly, just as fastening a twisted seat belt, a fatal injury may occur in the event of an accident.

### **No modification of the seat belt and no attachment of illegal fixtures**

- A modified seat belt cannot guarantee safety. Never modify the seat belt.
- Inappropriate work on safety units may adversely affect or hinder the operation of the units. Be sure to have the safety units serviced at a KG Mobility Corporation Authorized Service Center that possess the required expertise, knowledge and special tools.
- If you attach an auxiliary device or accessory to the seat belt separately, the seat belt may not operate normally. Never attach any auxiliary device or accessory to the seat belt.
- Do not loosen the seat belt by locking it with a clip or a clamp. Doing so may cause a fatal injury due to a secondary impact in the event of a collision.

### **Checking and managing the seat belt and the importance of safe driving**

- Do not allow foreign materials to enter into the seat belt buckle.
- If the seat belt and the relevant components are damaged, the seat belt may not operate normally. Check the seat belt frequently for any damage and the status of normal operation, and if any abnormality is discovered, have the seat belt repaired at a KG Mobility Corporation Authorized Service Center immediately.

- If a strong impact has been applied to the seat belt due to an accident, etc., make sure to have the seat belt checked and replaced with a new one as needed even if there is no abnormality visually. Also check and replace the retractor and the seat belt anchorage if there is an abnormality.
- Care should be taken to prevent the seat belt from being contaminated by polishes, oils, chemicals and especially battery acid. When cleaning, wipe the seat belt carefully using a neutral detergent and water. Replace the seat belt if the webbing is frayed, contaminated or damaged.
- Do not place a hard or sharp object in the clothes or a pocket where comes into contact with the seat belt.
- The seat belt can reduce serious injuries. However, it cannot block fatal accidents and injuries completely. Keep this in mind and drive safely.



# Child restraint for an infant or a small child

For an infant or a small child who cannot wear the three-point seat belt, have the infant or the small child be seated in a rear seat using a child restraint for an infant or a small child whose quality is certified by the government.

If the infant or the small child sits in the front passenger seat, the infant or the small child cannot be protected from an inflated air bag or other impacts in the event of a vehicle collision.



## Warning

### Seating an infant or a small child

- Do not let an infant or a small child sit in the front passenger seat. Doing so may cause a serious injury or death due to the inflation impact of the front air bag in the event of a collision accident.
- Do not ride with an infant or a small child in your arms or sitting on your lap. Doing so may cause a fatal injury to the infant or the small child in the event of a collision accident.
- If an occupant who is smaller than 140 cm wears the three-point seat belt, the seat belt cannot function fully. In such case, install and use a child restraint that fits the physical condition of the occupant.

### Installing the child restraint

- Never use a rearward facing child restraint on a seat Protected by an ACTIVE AIRBAG in front of it, DEATH or SERIOUS INJURY to the CHILD can occur.
- Use a child restraint for an infant or a small child that passed through the certification and the safety inspection carried out by a certified government agency. Follow the manufacturer's owner's manuals for the installation and precautions of the child restraint.
- If the child restraint for an infant or a small child is installed incorrectly, it may not provide the appropriate protection function. In such case, it may result in a serious risk when an accident occurs.
- If the child restraint for an infant or a small child is not secured completely, injury or death of an infant or a small child may occur in the event of a collision accident.
- Never install a rear-facing child restraint in the front seat with front passenger air bag.
- Install the child restraint for an infant or a small child on the left or right side of the rear seat where the three-point seat belt is installed. If it is installed on the front passenger seat, a fatal injury may occur when the air bag inflates.
- When installing the child restraint for an infant or a small child in the rear seat of a vehicle where a curtain air bag is installed, install it as far as possible from the door. Failure to do so may cause serious injury or death of an infant or a small child when the curtain air bag inflates.
- When the child restraint for an infant or a small child is installed on the rear seat where the three-point seat belt is installed, be careful not to position the seat belt across the neck or face of an infant or a small child.

### Using the child restraint

- When the child restraint for an infant or a small child is used, observe instructions provided by the manufacturer. Failure to do so may cause a fatal injury when an accident occurs.
- After installing the child restraint for an infant or a small child, make sure to check if it is secured correctly.
- Make sure that the child restraint is secured correctly by pushing or pulling it in various directions before letting an infant or a small child sit in the child restraint.

### Managing the child restraint

- Do not carry the child restraint for an infant or a small child in the vehicle without installing or securing it. Doing so may cause the child restraint to bounce, causing an injury to the occupants in the event of sudden braking or an accident.



## Caution

- This information is to help in understanding the necessity and usage of the child restraint for an infant or a small child. Use this information for reference purposes.
- When the child restraint for an infant or a small child is used, install and use it according to the owner's manual provided by the manufacturer.

## Infant and child safety

### Child Seat

Children that are too small to use the seat belts must be properly secured in a child restraint system.

#### Warning

- Never install a rear-facing child restraint in the front passenger seat with front passenger air bag.
- Because of the danger that an inflating passenger air bag could impact the rear-facing child restraint and kill the child.
- Use only the qualified child restraint systems. Follow the manufacturer's instructions for installation and use of the child restraint systems.
- Do not carry your child on your lap while driving. You cannot resist against the impact pressure in an accident. The child could be crushed between you and the parts of vehicle.
- Remember that a child restraint seat left in a concealed vehicle can cause it to be very hot. Check the seating surface before putting your child in the child restraint.
- When your child restraint is not in use, remove it from the vehicle or keep it secured with a seat belt to prevent it from being thrown forward in case of a sudden stop or an accident.
- When installing a child restraint, do not let the seat belts come across the child's neck.

### Table of Vehicle Handbook Information on Child Restraint Systems Installation Suitability for Various Seating Positions



Rear-facing child seat



Forward-facing child seat



TYPE A



TYPE B

Booster seat

Mass group	Restraint device figure	Front Passenger		Rear Centre <sup>*1)</sup>	Rear Out Board
		Air bag off	Air bag on		
0 ~ up to 10 kg (0 ~ 9 month)	Rear facing child seat	U	X	U	U
0+ ~ up to 13 kg (0 ~ 2 year)	Rear facing child seat	U	X	U	U
1 ~ 9 to 18 kg (9 month ~ 4 year)	Rear facing / Forward facing child seat	U	X	U	U
11 ~ 15 to 25 kg (4 year ~ 6 years)	Booster seat	U	U	U	U
111 ~ 22 to 36 kg (6 year ~ 12 years)	Booster seat	U	U	U	U

※ Child restraint system are classified into the 5 groups according to the ECE R44

\*1) Do not install a CRS with support leg in this seating position

#### NOTE:

U: Suitable for "universal" category restraints approved for use in the mass group.

UF: Suitable for forward-facing "universal" category restraints approved for use in the mass group.

L: Suitable for particular child restraints given on attached list. These restraints may be of the "semi-universal" categories.

X: Seat position not suitable for children in the mass group.

## Table of Vehicle Handbook Information on ISOFIX Child Restraint Systems Installation Suitability for Various ISOFIX Positions

Mass group	Size Class	Fixture	Vehicle ISOFIX Positions		
			Frnt Passenger	Rear Centre	Rear Out Board
CARRYCOT	F (1)	ISO/L1	X	X	X
	G (1)	ISO/L2	X	X	X
GROUP 0 UP TO 10KG	E (2)	ISO/R1	X	X	IL
GROUP 0+ UP TO 13KG	E (2)	ISO/R1	X	X	IL
	D (2)	ISO/R2	X	X	IL
	C (2)	ISO/R3	X	X	IL
GROUP I 9 TO 18KG	D (2)	ISO/R2	X	X	IL
	C (2)	ISO/R3	X	X	IL
	B (3)	ISO/F2	X	X	IUF/IL
	B1 (3)	ISO/F2X	X	X	IUF/IL
	A (3)	ISO/F3	X	X	IUF/IL

**NOTE:** Key of letters be inserted in the above table

IUF: Suitable for ISOFIX forward child restraints systems of universal category approved for use in this mass group.

IL: Suitable for particular ISOFIX child restraint systems (CRS) given in attached list. These ISOFIX CRS are those of the “specific vehicle”, “restricted” or “semi-universal” categories.

X: ISOFIX position not suitable ISOFIX child restraint systems in this mass group and/or this size class.

- (1) Some child seats are installed transversely and occupy two seats. Make sure that the feet of child are facing the door.
- (2) Slide the front seat forward all the way to install the rear-facing child restraint. Then, slide the front seat back as directed in the manual provided with the child restraint.
- (3) When using a forward-facing child restraint, do not slide the front seat backwards more than halfway for child's safety. In addition, do not tilt the front seat backrest backwards too far (max. 25°) and raise it as high as possible.

## Table of Vehicle Handbook Information for Installation in Various Seating Positions on i-Size Child Restraint Systems

Seating Posion	i-Size Child Restraint Systems
Front Passenger Outboard	X
Rear Outboard Left	i-U
Rear Outboard Right	i-U
Rear Center	X

### Key of letters to be inserted in the above table:

i-U: Suitable for i-Size "universal" Child Restraint Systems forward and rearward facing. (valid position for forward facing and rearward facing child restrant systems approved under ECE R129)

i-UF: Suitable for forward-facing i-Size "universal" Child Restraint Systems only.

X: Seating position not suitable for i-Size "universal" Child Restraint Systems.(invalid position for child restrant systems approved under ECE R129)

## List of suitable universal Child Restraint Systems (CRS)

Please read carefully the installation manual of your child restraint

Mass group	Child Restraint	Features
0	< 10 kg	-
0+	< 13 kg	Maxi Cosi CabrioFix
I	9 to 18 kg	Römer King II LS
II	15 to 25 kg	Römer KidFIX II XP SICT
III	22 to 36 kg	Römer KidFIX II XP SICT
		Peg-Perego Viaggio 2~3 shuttle

## List of suitable ISOFIX Child Restraint Systems (CRS)

Please read carefully the installation manual of your child restraint

Mass group	Child Restraint	Features
0	< 10 kg	-
0+	< 13 kg	Maxi Cosi CabrioFix & FamilyFix
I	9 to 18 kg	Römer Duo+
II	15 to 25 kg	Römer KidFIX II XP SICT
III	22 to 36 kg	Römer KidFIX II XP SICT
		Peg-Perego Viaggio 2~3 shuttle

## List of suitable i-Size Child Restraint Systems (CRS)

Please read carefully the installation manual of your child restraint

Mass group	Child Restraint	Features
67 cm - 105 cm ≤ 18.5 kg	Maxi Cosi 2way Pearl & 2wayFix	ISOFIX & Support Leg Rearward facing
> 15 months 105 cm ≤ 18.5 kg		ISOFIX & Support Leg Forward facing
100 cm - 135 cm	Besafe iZi Flex FIX i-size	ISOFIX & Support Leg (without side bumpers)

## Installation of crs secured by the seatbelt

### Front-facing Child Seat



Secure the child restraint with a seat belt as shown in the figure.



#### Caution

- When installing a child restraint system, follow the instructions provided by the manufacturer.



#### Warning

Do not use the car seat unless the followings are met.

The child seat may not perform as intended, which may result in a serious injury.

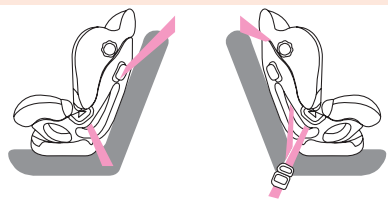

- Make sure that the buckle of the seat belt is securely engaged.
- Make sure that the seat belt is not loose or twisted.
- Make sure that the base does not move due to excessive play in all directions.
- You can't adjust the angle of the backrest with the child seat installed. If you're trying to do so, the seat belt will be slack, which incurs danger. Always adjust the angle of the backrest before installing the child seat.

### Rear-facing Child Seat



2

Secure the child restraint with a seat belt as shown in the figure.



#### Caution

- Never install a rear facing child restraint on the front seat without ensuring that the front airbag is deactivated. KG Mobility Corporation recommends that a child restraint to be installed on the rear seat.

When installing a child restraint, adjust the seat back angle as desired.



### Warning

**Do not use the child seat unless the followings are met.**

**The child seat may not perform as intended, which may result in a serious injury.**

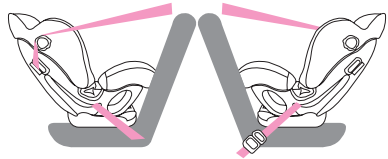

- **Make sure that the buckle of the seat belt is securely engaged.**
- **Make sure that the seat belt is not loose or twisted.**
- **Check if the angle of the backrest is set to 4 stage.**
- **Make sure that the base does not move due to excessive play in all directions.**
- **Make sure that the seat belt is routed through the rear-facing belt path and buckled up.**

# Securing a child restraint system with “ISOFIX/i-Size” system and “Tether Anchorage” system\*

ISOFIX/i-Size system is a standardised method of fitting child seats that eliminates the need to use the standard adult seatbelt to secure the seat in the vehicle.

This enables a much more secure and positive location with the added benefit of easier and quicker installation. An ISOFIX/i-Size-seat can only be installed if it has approval in accordance with the requirements of ECE R44 or ECE R129.

## Locations of ISOFIX/i-Size Lower Anchors and Top Tether

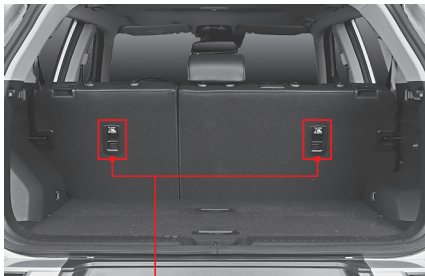

- 1 Two ISOFIX/i-Size lower anchors are installed at the bottom of the seatback at each outboard seat as shown in the figure.
- 2 The ISOFIX/i-Size lower anchors can be identified by the symbol attached on the top surface.



- 3 Two (for EURO countries) or three (Australia) ISOFIX/i-Size top tethers are installed at the upper side of seatback.

## How to use ISOFIX/i-Size Lower Anchor

The ISOFIX/i-Size lower anchor is exposed when you widen the space between seatback and cushion.



- 1 Now, you can see the ISOFIX/i-Size lower anchors.

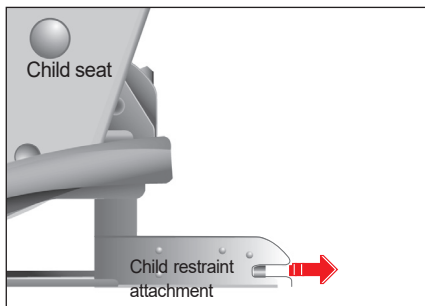

- 2 Insert the child restraint attachments into the ISOFIX/i-Size lower anchors until it clicks.
- 3 Adjust the seatback angle as desired.

**Warning**

- When using the ISOFIX/i-Size lower anchor, make sure that no interference are around the bar and the seat belt is not stuck.
- Rock the child restraint to check if it is securely installed. Refer to instructions provided by the manufacturer of the child restraint.
- Do not install the child restraint if it hinders the operations of front seat.

## How to use Top Tether

- 1 Adjust the seatback angle as desired.



- 2 Connect the top tether connector in child restraint to the top tether on the seatback of the second row seat.
- 3 Securely tighten the child restraint by adjusting the webbing of top tether connector.

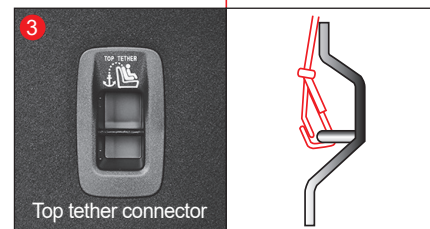
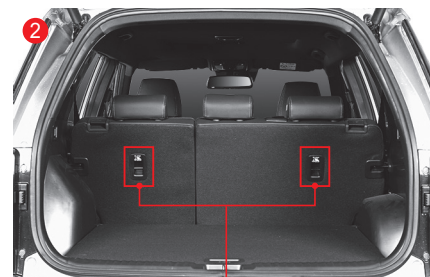



## Warning For Child Restraint

- **Use only the officially approved child restraint.**  
KG Mobility is not responsible for the personal injury and property damage due to the defect of child restraint.
- **These seats are subject to the ECE R44 or ECE R129 standard.**
- **Use only the child restraint with proper type and size for your baby.**
- **Use only the child restraint at proper location.**
- **Child restraint has 5 categories based on the weight as below according to ECE R44.:**  
GROUP 0: 0 ~ 10KG  
GROUP 0+: 0 ~ 13KG  
GROUP I: 9 ~ 18KG  
GROUP II: 15 ~ 25KG  
GROUP III: 22 ~ 36KG
- **Group 0 & 0+**  
Rear facing child restraint fitted on the rear seat
- **Group I**  
Rear facing or forward facing child restraint fitted on the rear seat
- **Group II & III**  
Booster seat fitted on the rear seat with seat belt fastened  
  
Always follow the installation and use instructions provided by the manufacturer of the booster seat.

- **i-Size:** child seats with i-Size approval must meet the requirements prescribed in the ECE R129 standard in relation to installation and safety. Child seat manufacturers can tell you which seats have i-Size approval for this vehicle.



### Caution

- **Top tether is the supplemental device to secure the child restraint system after engaging it by the lower latches. Therefore, do not secure the child restraint system only with the top tether. The increased load may cause the hooks or anchors to break, causing serious injury or death.**
- **If a child restraint is not properly secured to the vehicle and a child is not properly restrained in the child restraint, the child could be seriously injured or killed in a collision. Always follow the instructions provided by the manufacturer for installation.**
- **Make sure the latches of the child restraint system are latched to the lower latches. In this case, you can hear the “click” sound.**
- **The child restraint seat strap may not work properly if attached somewhere other than the correct top tether.**
- **Make sure that the child restraint system is firmly secured by rocking it in different directions.**
- **Incorrectly installed child restraint system may cause an unexpected personal injury.**

## Air bag\*

The air bag is an ancillary safety unit that inflates instantaneously in the event of a vehicle collision, protecting an occupant from the impact.

The air bag system is composed of the air bag crash sensor, air bag control module and air bag.

The air bag operates according to various factors including the strength and direction of a vehicle collision, strength of a colliding object, vehicle speed and the condition of the occupant.

### Warning

- The air bag is an auxiliary unit that supplements the protection function of the seat belt and it cannot replace the seat belt. The seat belt should be fastened during driving.
- The air bag includes electric sensors and control modules and it only operates when the ignition switch is in the On position or the engine is running.
- The air bag is installed on the part where “AIRBAG” is displayed. Do not apply an impact to, place an article on or attach an accessory to the part where the air bag is installed. Doing so may cause a serious injury when the air bag inflates.
- When 10 years have passed after the air bag is installed, make sure to have the air bag checked at a KG Mobility Corporation Authorized Service Center even if there is no abnormality in the air bag system visually.

## Air bag warning label

The air bag warning label displaying the risk of secondary damages in case the air bag inflates and safety information is attached to the passenger side sun visor. Read and familiarize yourself with the safety information before driving.



### Warning

- The air bag is a unit that explodes a type of gunpowder in the unit and inflates the air bag instantaneously to protect the occupant. Therefore, noise, glare and smoke occur due to the explosion of gunpowder when the air bag inflates.
- The occupant may get burned when the air bag inflates. In some cases, the occupant may suffer injuries such as a bruise, bone fracture, abrasion and facial blows due to the inflated air bag and secondary damages such as broken glass.

## Air bag warning lamp

The air bag warning lamp turns on when the ignition switch is turned On, and it turns off when there is no abnormality in the air bag system.

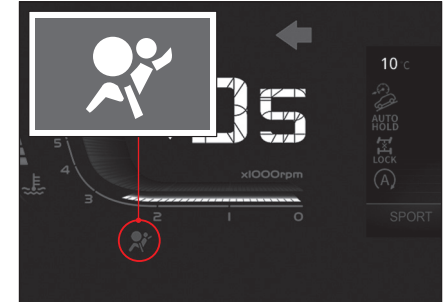

### Warning

- If the air bag warning lamp stays on continuously, it indicates that there is abnormality in the air bag or the seat belt pretensioner system. Have your vehicle checked and serviced at a KG Mobility Corporation Authorized Service Center immediately.

## Air bag crash sensor and air bag control module

The vehicle is equipped with sensors that can detect a collision and a module that controls the air bag operation.



- 1 Air bag control module
- 2 Front impact sensor (G-sensor type)
- 3 Side impact sensor (pressure sensor type)
- 4 Side impact sensor (G-sensor type)

## Configuration of air bag

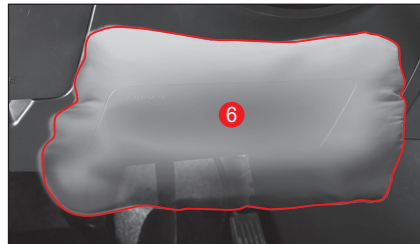
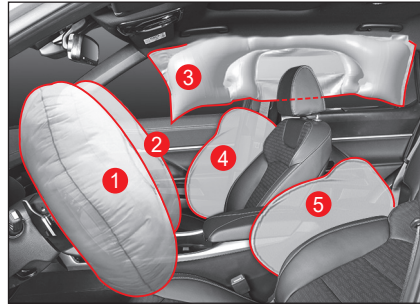

- 1 Driver air bag
- 2 Front passenger air bag
- 3 Curtain air bag
- 4 Front seat side air bag
- 5 Far side air bag
- 6 Driver knee air bag

## Passenger Air Bag ON/OFF Switch\*



The front passenger air bag is disabled (not inflatable) when placing the passenger air bag ON/OFF switch to "OFF" position. This switch is located on the right side of the instrument panel, and you can see it when opening the front passenger door. Press and turn this switch to operate.

"OFF" position: disabled (not inflatable)

"ON" position: enabled (inflatable)

## Driver air bag

The driver air bag protects the driver's head in the event of a front collision.

The driver air bag is installed in the center of the steering wheel.



### Warning

- The driver should sit as far as possible from the steering wheel within the range that it does not hinder the driver from controlling the vehicle. If the driver sits too close to the steering wheel, a fatal injury may occur when the air bag inflates.
- Do not place any object on or attach an accessory or a sticker to the air bag cover (steering wheel cover). Doing so may hinder the air bag from operating normally and increase a risk of injury when the air bag inflates.

## Driver knee air bag

The driver knee air bag operates along with the driver air bag at the same time in the event of a front collision, protecting the driver's knees.

The driver knee air bag is installed in the dashboard under the steering wheel.

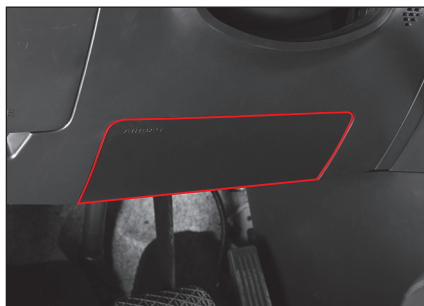

### Warning

- Sit as far as possible from the dashboard where the front passenger air bag is installed. If the front passenger sits too close to the dashboard, a fatal injury may occur when the air bag inflates.

### Notice

- The front passenger air bag operates along with the driver air bag at the same time.

## Front passenger air bag

The front passenger air bag protects the front passenger's head in the event of a front collision.

The front passenger air bag is installed inside of the dashboard in front of the front passenger seat.

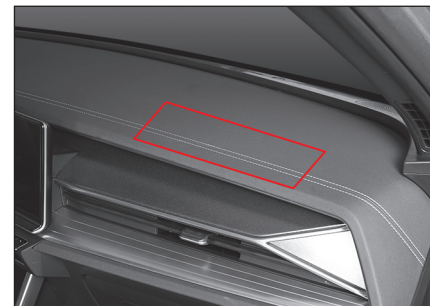

## Front seat side air bag

The front seat side air bag protects the side of the front seat occupant in the event of a side collision that meets the condition for inflating the air bag.

The front seat side air bag is mounted in the side of the driver seat backrest and the front passenger seat backrest.



### Warning

- Do not hang clothes or accessories or use seat covers on the seats where the side air bag is mounted.
- Do not apply impact to the area where the collision detection sensor for the side air bag (front seat backrest) is installed. Doing so may cause the side air bag to malfunction.

## Far side air bag

The far side airbag unfolds between the passenger and the driver in the event of a side collision to prevent the passengers from being injured by a physical collision between them.



### Warning

- Do not use seat covers or hang clothes/ accessories on the seats with far side air bag.

## Curtain air bag

The curtain air bag protects the head of the front seat occupants and the rear seat occupants in the event of a side collision that meets the condition for inflating the air bag.

The curtain air bag is mounted on the roof at the top of the front and rear doors on both sides.



### Warning

- Do not apply impact to the curtain air bag crash sensor (bottom part of the B pillar). Doing so may cause the curtain air bag to malfunction.
- Do not slam the door. Doing so may cause the air bag to malfunction.

### Notice

- The side air bags and the curtain air bags operate at the same time in the event of a side collision, but the left and right side air bags and curtain air bags operate separately.

## Cases where the air bag does not inflate

The air bag does not inflate in all collision accidents. The air bag may not inflate, in any of the following cases:

### In the event of a slight collision

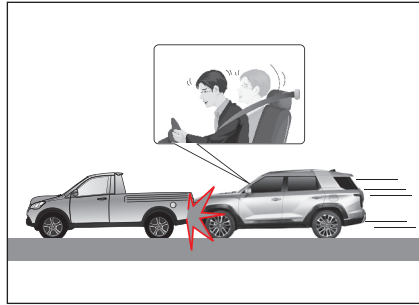

The air bag may not inflate in the event of a slight collision that the collision detection sensor cannot detect or the strength of collision is weak.

In such case, the seat belt can provide enough protection and the air bag operation may instead give secondary damages to the occupant such as a burn or an injury.

### In the event of a rear end collision

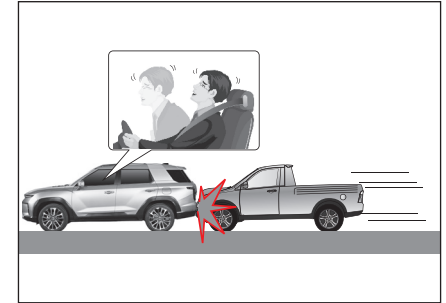

In the event of a rear end collision by another vehicle, the body of the occupants move backwards, so the air bag cannot provide enough protection even if it inflates. In such case, the air bag may not inflate.

### In the event of a side collision

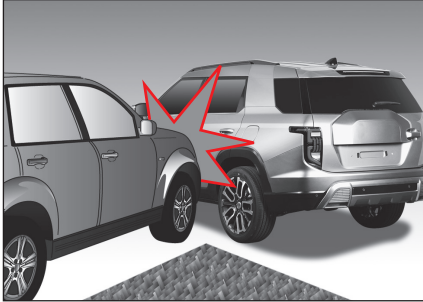

In the event of a side collision, the occupants cannot be protected by the front air bags, so the front air bags may not inflate.

However, the curtain air bags and the side air bags operate depending on the degree of impact in the event of a side collision, protecting the front seat occupants.

### In the event of a diagonal collision

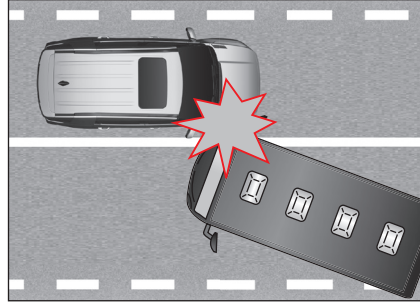

Since the impact of a collision in the diagonal direction is weaker than the impact of a collision in the front or side direction, the air bag may not inflate.

### In the event of a collision with a narrow object



In the event of a collision with a narrow object such as a street light, utility pole or tree, the degree of impact applied to the sensor may not be enough, so the air bag may not inflate.

### In case the vehicle moves beneath another vehicle

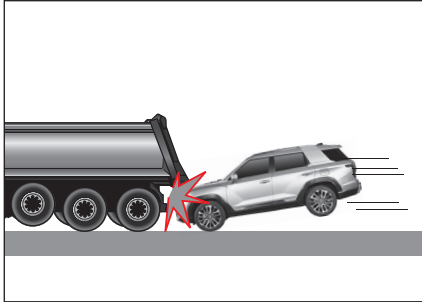

Generally, most drivers apply a sudden brake when an accident occurs, so the front part of the vehicle becomes lower. Therefore, the vehicle often moves beneath the opposing vehicle in the event of an accident against a tall vehicle such as a bus or a truck. In such case, the air bag may not inflate.

### In the event of a rollover accident

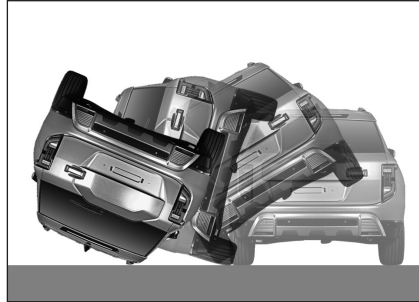

If the vehicle turns over or rolls over, the occupant cannot be protected fully by the air bag alone. In such case, the air bag may not inflate.

However, the curtain air bag or the side air bag may inflate according to the degree of impact applied to the side when the vehicle turns over.

### Secondary injury due to air bag deployment



If the air bag control module detects the impact during an accident, it transmits the signal to deploy the air bag. This signal triggers the explosion of the powder, which is included in the air bag module, and the air bag deploys in a very short time to protect the occupants. When the air bag inflates, there will be heavy noise, glare and smoke. You could suffer secondary injuries caused by inflated air bag such as an abrasion, a bruise, a burn or injury by broken glasses.



## Other cases

### Cases where the driver/front passenger air bags do not inflate

- When the air bag warning lamp is on
- When an impact is applied to the top of the engine hood by a falling rock, etc.
- When the vehicle falls into a drainage ditch or a puddle

### Cases where the side air bags or curtain air bags do not inflate

- When the air bag warning lamp is on
- In case of a front or rear collision
- When the vehicle rolls over or turns over in the side direction with a moderate degree of impact

## Warnings for the air bag



### Warning

#### Seating an infant or a small child

- Do not let an infant or a small child sit in the front passenger seat or ride with an infant or a small child in your arms. The infant or the small child and you may get seriously injured or killed when the air bag inflates.
- Do not install a child restraint for an infant or a small child in the front passenger seat. If the air bag inflates, the infant or the small child may get seriously injured or killed due to the impact.
- When installing the child restraint for an infant or a small child in the rear seat of a vehicle where the curtain air bag is installed, install it as far as possible from the door. Failure to do so may cause serious injury or death of an infant or a small child when the curtain air bag inflates.

#### Driving and riding position

- Only hold the rim of the steering wheel when driving. Doing so ensures that the air bag inflates fully when it operates.
- Do not lean against the steering wheel or maintain your arms in an “X” shape. You may get seriously injured when there is a problem in the air bag operation or the air bag inflates.
- Do not drive while leaning forward or come too close to the steering wheel. You may get hit by the air bag and seriously injured on your head and neck or even killed before it inflates fully.
- If you wear the seat belt in an unstable position or while leaning to one side, the air bag cannot provide enough protection. You may even get seriously injured by the air bag.
- Do not place your feet or hands on the dashboard. You may get seriously injured when the air bag inflates.
- Do not lean against the door or stick your arm out of the window. You may get seriously injured when the curtain air bag inflates.

### Handling the air bag

- Do not apply impact to air bag-related devices including the steering wheel, the part where the air bag is installed, wires and the seat belt pretensioner system. You may get seriously injured when the air bag inflates suddenly.
- Do not apply impact to the seat backrest where the side air bag is installed. Doing so may cause the side air bag to malfunction.
- Do not slam the door when closing the door. Doing so may cause the curtain air bag or the front air bag to malfunction.
- Do not place any object between the air bag and the occupant. Doing so may hinder the operation of the air bag and you may get injured by such an object when the air bag inflates.
- After the air bag and the seat belt pretensioner operate, their relevant components become very hot. Never touch such components until they have cooled down.

### Operation of the air bag

- The air bag is a unit that protects the life of a passenger from a sudden accident, and it inflates at high speed by hot gas. The occupant may suffer injuries such as a burn, abrasion or bruise according to the circumstances at the time when the air bag inflates.
- A loud noise, dust, smoke or gas that occurs when the air bag or the seat belt pretensioner operates is normal.
- Gas generated when the air bag or the seat belt pretensioner operates is nontoxic, but if your skin, eyes or nose becomes irritated, wash with clean water. If the symptom persists, consult your doctor.
- Caution should be taken that the windshield or window glasses may be broken due to an impact from the operation of the front seat air bag or curtain air bag.

### Do not modify the air bag or change the structure

- Do not modify or change the structure of any air bag-related devices including the steering wheel, the part where the air bag is installed or the wires. Do not check an air bag-related circuit with a tester. Doing so may cause the air bag system to malfunction or break down, resulting in personal injury and property damage.
- Do not replace the steering wheel with a product which is not a KG Mobility Corporation genuine part. Doing so may cause the air bag in the steering wheel not to operate normally.

# Tire pressure monitoring system (TPMS)\*

The tire pressure monitoring system (TPMS) is an auxiliary safety unit that detects if the tire pressure is abnormally high or low and informs such fact to the driver, preventing an accident that may occur due to the tire pressure.

- The global warning light (⚠) comes on if the tire pressure is abnormal.
- Also, if there is abnormality in the tire pressure monitoring system (including the sensor), the global warning light (⚠) blinks and stays on.

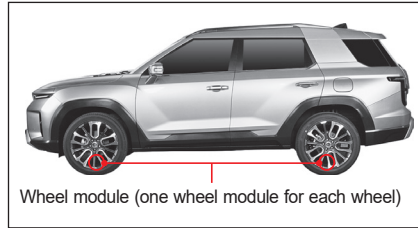

The electronic control unit of the TPMS receives various data including the tire pressure and temperature from the wheel module mounted on each wheel and displays such data on the instrument cluster.

- Proper tire pressure: 34 psi, 2.3 bar
- The proper tire pressure is the value measured at room temperature (20 °C) in the condition of an empty vehicle when the tires have been cooled properly.

## Notice

- If the vehicle is driven at a speed of 20 km/h or faster after the engine is started, the tire pressure is detected within 5 minutes although it might be slightly different depending on the system status. If the tire pressure is not sensed, “...” will be displayed.

## ⚠ Caution

- The tire pressure displayed on the display of the instrument cluster can be changed by various environmental factors including the driving status of the vehicle, number of occupants in the vehicle and the status of air injection into the tires.
- When air is injected into a tire, airs with different temperature are mixed, so the tire pressure may be changed until a temperature balance is reached.

2

## Checking the tire pressure

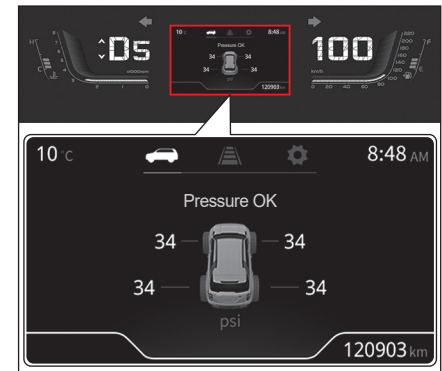

By selecting TPMS status from the main menu of the instrument cluster, you can check all tire pressures from the display of the instrument cluster.

## If the tire pressure or the TPMS is abnormal

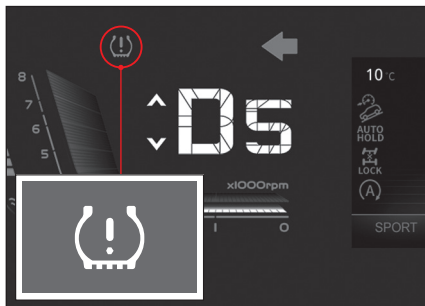

If the tire pressure or the tire pressure monitoring system is abnormal, the global warning light blinks or comes on.

- Abnormal tire pressure (low/flat): The global warning light stays on.
- Abnormal tire pressure monitoring system (including the sensor): The global warning light blinks for approximately 70 seconds and stays on.



### Warning



- If the global warning light comes on in the instrument cluster, the tire pressure is insufficient, excessive or uneven. Make sure to park your vehicle at a safe place and check the tire pressure.
- If the global warning light stays on after checking the tire pressures, starting the engine and driving the vehicle for more than 10 minutes at a speed over 20km/h, have your vehicle checked and serviced at a KG Mobility Corporation Authorized Service Center.
- A sudden tire damage due to an external factor such as a nail or a road debris, etc. may not be detected immediately. If the vehicle becomes unstable while driving, slow down, move the vehicle to a safe place and check the vehicle.
- Do not modify or remodel your vehicle in a way that hinders the operation of the TPMS.
- For safety, always use genuine wheels equipped with the tire pressure monitoring sensor.

### Caution

- Adjust the tire pressure when the tires are cold (no driving for 2 or 3 hours).
- Even if the tire pressure has been adjusted to a proper tire pressure, the global warning light () may come on due to a difference in the internal tire temperature and air temperature. This is the phenomenon that the tire pressure drops in proportion to the temperature and this does not indicate that the TPMS is abnormal.
- If you need to drive while the ambient temperature rises or drops rapidly, check and adjust your tire pressure to the prescribed inflation pressure in advance before driving.
- For safe driving, check your tire pressure regularly without simply depending on the TPMS.

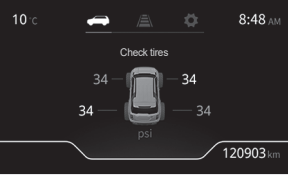
## Display of the TPMS status on the instrument cluster

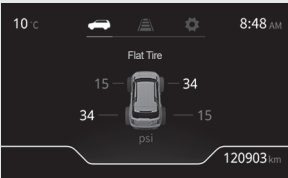
Item	Main menu	Operating condition
Tire pressure OK		<ul style="list-style-type: none"> <li>It is displayed when the tire pressure is normal.</li> </ul>
Low pressure		<ul style="list-style-type: none"> <li>In order to detect whether the tire pressure is normal or insufficient, the TPMS wheel module must be properly installed on each wheel. After IGN ON, it takes several seconds for the TPMS ECU and TPMS wheel module to communicate normally, and during this time, each state is displayed.</li> </ul>
		<ul style="list-style-type: none"> <li>It is displayed when the tire pressure is insufficient to the extent that it is to be checked (approximately 20% less than the specified tire pressure). The corresponding tire's pressure indicator blinks (alternating white and red) and the global warning light turns on.</li> </ul>
Check tires		<ul style="list-style-type: none"> <li>It is displayed when the tire pressure is insufficient to the extent that it is to be checked (approximately 23.9 psi or less). The corresponding tire's pressure indicator blinks (alternating white and red) and the global warning light turns on.</li> </ul>

Item	Main menu	Operating condition
Flat tire		<ul style="list-style-type: none"> <li>It is displayed when the tire pressure drops sharply or there is a flat tire. The corresponding tire's pressure indicator blinks (alternating white and red) and the global warning light turns on.</li> </ul>
High pressure		<ul style="list-style-type: none"> <li>It is displayed when the tire pressure is excessive. The corresponding tire's pressure indicator blinks (alternating white and red).</li> </ul>
Pressure imbalance		<ul style="list-style-type: none"> <li>If the left/right tire pressure differs by more than 5 psi, the corresponding tire pressure indicator blinks (alternating white and orange).</li> </ul>

<p><b>Notice</b></p>	<ul style="list-style-type: none"> <li>If a certain tire pressure is shown as “--” while the other tire pressures are shown normally, the TPMS wheel module of the relevant tire may be abnormal. Have your vehicle checked and serviced at a KG Mobility Corporation Authorized Service Center immediately.</li> <li>If all tire pressures are displayed as “--”, it is possible that two or more TPMS wheel modules are defective or communication with the ECU has failed. In this case, immediately have the vehicle checked and serviced at a KG Mobility Dealer or KG Mobility Authorized Service Center.</li> </ul>
----------------------	--

## When low tire pressure is detected

When a tire with significantly low pressure is detected, the global warning light () comes on and the position of the relevant tire with low pressure is indicated on the instrument cluster.

In such case, slow down, bring your vehicle to a KG Mobility Corporation Authorized Service Center and have your vehicle checked and serviced.



### Caution

- If you drive the vehicle continuously with a low tire pressure, the life of the tires, vehicle operating force, brake force and vehicle fuel efficiency may decrease.
- If you cannot bring your vehicle to a KG Mobility Corporation Authorized Service Center, add air to the tire using the service kit for tire repair.

 Refer to "Inflating a tire" (p.5-15)

## When you have rotated the tires

When you have rotated the tires, the TPMS resets the position of each tire.

If the vehicle is driven at a speed of 20 km/h or faster, typically the system completes the reset within 5 minutes although it might be slightly different depending on the system status.

 Refer to "Rotating the tire positions" (p.6-38)



### Warning

- If you replace a tire where sealant has been injected for repairing the tire, be sure to have the exterior of the TPMS sensor and the TPMS checked for normal operation at a KG Mobility Corporation Authorized Service Center.



### Caution

- If you rotated the tires or replaced a wheel module including the tire pressure detection sensor, the tire position may not be recognized correctly at the beginning of driving so that the previous tire pressure may be displayed or the global warning light () may turn on. This is a temporary state which is not a failure.
- The time taken for resetting the tire position may vary depending on the driving condition of the vehicle.

## Cautions for the TPMS



### Caution

- If a wheel without a wheel module (tire pressure detection sensor) is installed to the vehicle, the global warning light turns on and the TPMS does not operate.
- Do not rely too much on the TPMS and be sure to check the tire pressure status before driving the vehicle.
- The TPMS operates in a way that it communicates with the wheel module by wireless. Therefore, if an electronic device such as a mobile speed camera detector that can create radio interference is installed to the vehicle, the TPMS may not operate normally.
- In an area with a strong electromagnetic field (police stations, government offices, broadcasting stations, military facilities, transmitting towers, etc.), the TPMS may fail and the global warning light (⚠) may turn on.
- If any foreign object is caught in the transmitter attached to the tire wheels while driving on a muddy or snowy road, hindering the communication with the receiver of the vehicle, the radio interference occurs due to strong external waves or a metal object is located near the TPMS, the tire pressure may be displayed with a time delay or may not be displayed normally.

- When you drive the vehicle with snow chains installed, the snow chains may hinder the communication between the wheel module and the antenna so that the TPMS may not operate normally. However, this does not impair the operation of the vehicle.
- When air is injected into a tire, the tire pressure displayed on the air injection device may be different from the tire pressure displayed on the TPMS. This difference is caused by factors including the driving status of the vehicle, number of occupants in the vehicle and the status of air injection into the tire and this does not indicate the failure of the TPMS.
- Be careful not to damage the wheel module when the tires are replaced. If the wheel module receives an impact or is damaged when the tires are replaced, the tire pressure detection function does not operate.
- If you have your tires replaced at a tire shop other than a KG Mobility Corporation Authorized Service Center, be sure to inform that the TPMS has been fitted to the tires.
- The life of the battery in the tire pressure detection sensor (wheel module) may be reduced if abnormalities such as checking tire pressure, low pressure, high pressure and pressure imbalance occur frequently.



## Immobilizer system\*

The immobilizer system is a vehicle anti-theft system that prevents it from starting the engine unless a permitted key is used.

The engine can be started only when the code of the transponder integrated in the smart key (rekes key) has been authenticated by comparing it with the code of the engine control unit.

### ⚠ Caution

- **The immobilizer system cannot be removed from the vehicle under any circumstance. If you arbitrarily remove or damage the immobilizer system, you cannot start the engine. Never remove, damage or modify the immobilizer system.**
- **The immobilizer system should be repaired only by a licensed technician at a KG Mobility Corporation Authorized Service Center.**
- **When the code of the transponder is deleted or an additional key is registered, observe the process in person.**
- **Do not install a metallic accessory near the smart key (rekes key) or the ignition switch. Such accessory changes the signal delivered to the ignition switch, preventing it from starting the engine.**
- **Do not drop the smart key (rekes key) or apply impact to it. Doing so may damage the transponder.**
- **Do not modify the vehicle arbitrarily to install a remote starting device. Doing so may cause a problem in starting the engine or a fatal accident.**

## Immobilizer/smart key warning light

If the immobilizer or the smart key system is abnormal, the immobilizer/smart key warning light will blink.

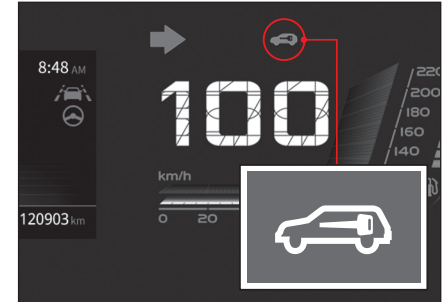

### Notice

- **The communication time between the transponder and the engine control unit varies depending on the case. If the communication time is short, the warning lamp may not be lit.**

## If the engine does not start

In the event of the communication error between the transponder and the engine control unit due to a system internal fault or external communication obstacle, the engine will not start.

In such case, the immobilizer warning light will blink.

You may not be able to start the engine in a vehicle with the immobilizer system, in any of the following cases:

- When two or more smart keys come into contact with each other are used
- When the smart keys is used near a device that sends or receives electromagnetic fields or waves
- When the smart keys is used near electric or electronic devices such as lighting equipment, security keys or security cards
- When the smart keys is used near a key chain, a magnet, a metallic object or a battery
- When you start the engine before the engine preheating time ends



### Caution

- **You may not be able to start the engine due to an external factor (key chain, magnet, etc.) or early starting before the engine preheating time to cause communication failure with the immobilizer. In such case, eliminate the factor preventing it from starting the engine, place the smart key outside the operation range of the antenna for approximately 10 seconds or longer and start the engine again.**
- **If the immobilizer/smart key warning light blinks continuously and you still cannot start the engine after eliminating the external factor, have your vehicle checked and serviced at a KG Mobility Authorized Service Center.**

## When the transponder is damaged

You can't start the engine with a key whose transponder is damaged. In such case, replace the smart key with a new one and register the relevant code on the engine control unit.

## When you lose the key

When you lose your key, the transponder code of the lost key registered on the engine control unit should be deleted.

Have KG Mobility Authorized Service Center take measures for preventing vehicle theft by a lost key.

## Theft deterrent system

The theft deterrent system is a device that prevents theft of the vehicle by activating the anti-theft alarm when the door, tailgate or engine hood is open in an armed mode.

### Entering the theft monitoring mode

When the door lock button (including the door lock/unlock button on the exterior of the front doors) of the remote key or smart key is pressed with all doors, tailgate and engine hood closed, the system enters the theft monitoring mode.

- When the system enters the theft monitoring mode, the warning light blinkstwice and the warning buzzer sounds once.
- **Remote control key:** When the theft deterrent system is armed, the hazard flashers blink twice. However, if you press this button once again in 4 seconds, the hazard flashers blink twice and the buzzer sound once.
- **Smart key:** When the theft deterrent system is armed, the hazard flashers blink twice and the buzzer sound once.
- If approximately 30 seconds have passed without opening the door after unlocking the door using the remote key or smart key in the theft monitoring mode, all doors are locked again and the system enters theft monitoring mode.



#### Caution

- **If you insert the key into the door key hole and lock the doors, only the doors are locked but the theft deterrent system is not activated.**
- **The system enters the theft monitoring mode only when the ignition switch is on Off and all doors, tailgate and engine hood are closed completely.**
- **If the ignition switch is on Acc or On or the engine is being started, the system does not enter the theft monitoring mode.**

## Activating the theft alarm

In the theft monitoring mode, the warning light and the warning buzzer operate at an interval of 1 second for 30 seconds in any of the following cases:

- When an attempt to open the door, tailgate or engine hood without using the smart key is made
- When the key is inserted into the key hole to open the door
- When the door lock lever is placed in the unlock position forcibly

When the theft deterrent system is activated, the alarm stops in any of the following cases: However, the theft monitoring mode is maintained at this time.

- When the door lock button or door unlock button on the smart key is pressed
- When the door lock/unlock button on the exterior of the front door is pressed
- When the ignition switch is On
- **Remote control key:** pressing “Lock”, “Unlock”, “Panic” button on the remote control key, or turning the ignition switch to “ON” position
- **Smart key:** pressing “Lock” or “Unlock” button on the Smart key, pressing the “Lock/Unlock” button on the outside door handle, or turning the ignition switch to “ON” mode by pressing it.

## Holding the theft alarm

The alarm does not sound and is on hold in any of the following cases:

- When the tailgate is opened by pressing the open tailgate button on the smart key
- When the tailgate is opened by pressing the open button inside the tailgate door handle with the smart key detected

### Notice

- **An armed mode is maintained even if the tailgate is open in an anti-theft alarm hold state. When the tailgate is closed, it also returns to an armed mode.**

## Canceling the theft monitoring mode

The theft monitoring mode is canceled when the door is switched to the Unlock position using the remote key or smart key (including the door lock/unlock button on the exterior of the front doors).

### Notice

- **When the theft monitoring mode is canceled, the warning light blinksonce and the warning buzzer sounds twice.**
- **All doors are locked again and the system enters theft monitoring mode, when approximately 30 seconds have passed without opening the door after unlocking the door using the smart key in the theft monitoring mode.**

## **3. Convenient Equipment**

You can check information regarding devices that allow you to drive the vehicle conveniently and wisely and how to use such devices.

An explanation is provided for doors, seats, windows as well as various convenient equipment including the tailgate, various lights and lamps, mirrors, heater and air conditioner, Smart Audio, storage and cargo box.

## How To Lock/Unlock & Open Door

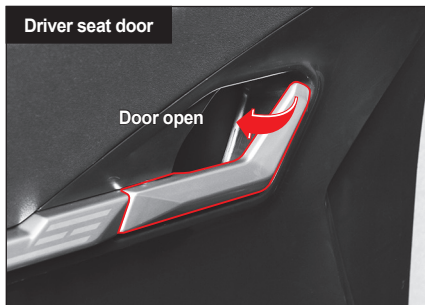

### Door Opening Lever

- Driver door opening lever  
Pulling the door opening lever with the door locked will unlock all doors and open the driver's door.
- Front passenger door opening lever  
Pulling the door opening lever with the door locked will unlock all doors. At this time, pull the door opening lever again to open the front passenger's door.
- Rear door opening lever  
Pulling the door opening lever with the door locked will unlock that rear door only. At this time, pull the door opening lever again to open the door.

### Warning

- Take care not to allow the door to open by pulling the door opening lever while driving. If any door is open while driving it can pose a serious risk.

### How To Check If Door Locked/Unlocked

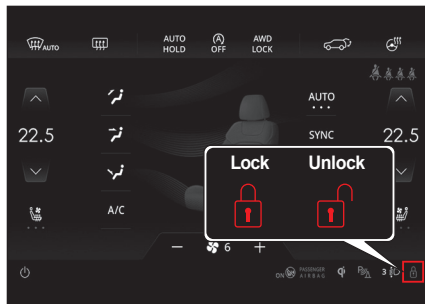

- The buttonless integrated control panel allows you to confirm that the door is locked/unlocked.

### Notice

- When any door is unlocked, the door unlock indicator is displayed.

### Door Lock/Unlock button

Each time the door Lock/Unlock button on the driver seat is pressed, the status of all doors and the tailgate is changed between locked and unlocked alternately.



### Caution

- You cannot lock the door using the door Lock/Unlock button or the smart key when the door is opened even slightly.
- You cannot unlock the door with the driver door Lock/Unlock button in theft monitoring mode.



### Warning

- Before driving the vehicle, lock all doors from the driver seat using the door lock/unlock lever. Be sure to drive the vehicle with all doors locked when a child is present in the vehicle. If the door is opened suddenly while driving, you may face a serious risk.
- Before you get out of the vehicle, check the rear and front sides of the vehicle first to see if there is any vehicle, motor cycle, bicycle or person passing by. In particular, opening the door without checking the rear side may lead to an accident.

## Auto door lock function at the time of driving

When the vehicle speed exceeds the set speed, all doors and tailgate are automatically locked.

### Notice

You can set at **User setting** → **Door / Tailgate** → **Auto lock** under  (user settings) in the instrument cluster.

## Auto door unlock function at the time of collision

When a collision accident occurs with all doors locked and the air bag is activated, all doors are unlocked automatically.



### Warning

- If the vehicle body or a door has been deformed due to an impact from an accident, the auto door unlock function may not operate normally.

## How To Lock Doors In Emergency

If you cannot lock the doors using a smart key because of dead battery, wave interference or etc., you may use the mechanical key (secondary key) to lock the doors manually. (excluding driver door)

☞ Refer to “Unfolding/folding the emergency key” (p.4-17)

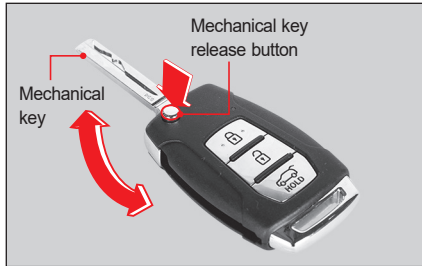

- Pull out the mechanical key by pressing the mechanical key release button of the smart key/REKES key.
- To fold in the mechanical key, fold the mechanical key while pressing the mechanical key release button.

### ⚠ Caution

- **Attempting to fold in the mechanical key without pressing the mechanical key release button can lead to smart key breakage.**

## To lock doors with mechanical key (excluding driver door)

- 1 Open the door, insert the mechanical key into the emergency lock located behind the door and turn the key in the direction of the arrow.

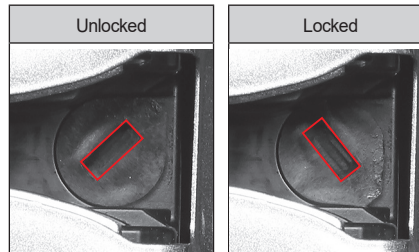

- 2 Close the door with the groove of the emergency lock still locked.

### ⚠ Caution

- **If the door is locked using an emergency lock, the door can be unlocked using the Smart key/REKES key or by pulling the door opening lever from the vehicle interior.**



## Child safety door lock

The child safety door lock is installed in order to prevent a child from opening the door in the vehicle when a child is present in the rear seats.

The child safety door lock is provided at the inner side of the rear seat doors.



## Locking/unlocking the door lock

When the child safety door lock is locked, the rear seat doors cannot be opened with the door open lever in the vehicle even if the rear seat doors are unlocked. In such case, the rear seat doors can be opened only from the outside of the vehicle.

### Locking the child safety door lock

Place the child safety door lock lever in the lock position by turning it counterclockwise.

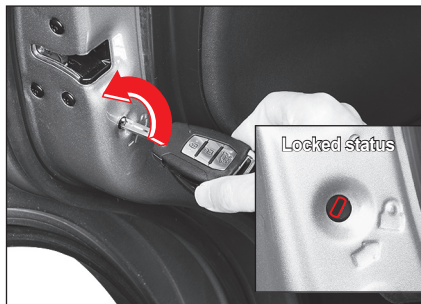

### Unlocking the child safety door lock

Place the child safety door lock lever in the unlock position by turning it clockwise.



3

#### Warning

- When a child is present in the vehicle, place the child safety door lock lever in the lock position to prevent the child from opening the door in the vehicle.

## Seat & adjustment switch / button / lever

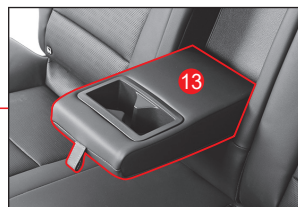
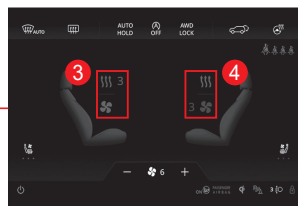
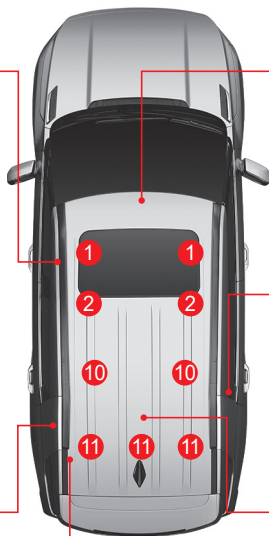

### Front seat

- 1 Front seat
- 2 Sliding headrest
- 3 Driver seat ventilation and heating switch (LTCM)
- 4 Front passenger seat ventilation and heating switch (LTCM)
- 5 Backrest angle control lever
- 6 Seat cushion angle control lever
- 7 Seat height control lever
- 8 Seat front and rear position control lever
- 9 Lumbar support control button (driver seat)

### Rear seat

- 10 Rear seat (6:4 split type)
- 11 Headrest
- 12 Rear seat warmer button
- 13 Rear armrest (cup holder)
- 14 Rear seat webbing guide
- 15 Seatback reclining adjustment lever (folding)

## Front seat

### Adjusting the headrest

#### Adjusting the front and rear angles

- Push the rear section of the headrest (1) in the arrow direction. The angle of the headrest can be adjusted in 3 levels.
- To return the headrest to its original position, push it to the end in the arrow direction again and release it.

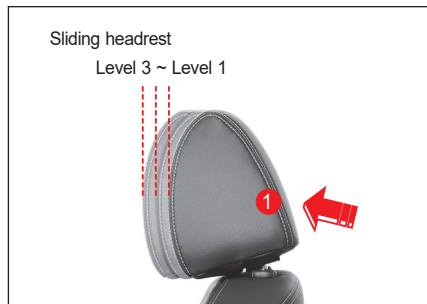

### Adjusting the height

- To raise the headrest, hold and pull the headrest up.
- To lower the headrest, push the headrest down with the Lock button (1) pressed in the arrow direction.

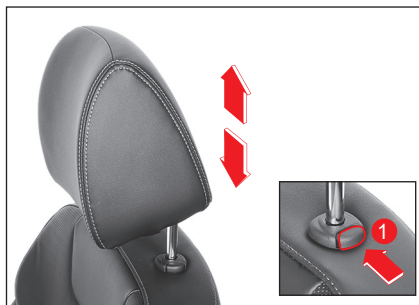

#### Notice

- Adjust the height of the headrest so that the center of the headrest is aligned with the occupant's eye level.
- It may not be possible to align the center of the headrest with the occupant's eye level due to the occupant's physical condition. In such case, align the height of the headrest with the highest position for a tall person and the lowest position for a short person.

### Separation/installation

#### Separating the headrest

- 1 Recline the seat backrest to secure necessary space for separating the headrest safely.
- 2 With the Lock button (1) pressed in the arrow direction, separate the headrest by lifting it to the end.

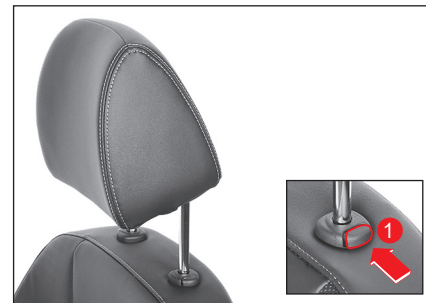

- 3 Return the seat backrest to its original position.

#### Warning

- Never drive the vehicle with the headrest separated. Doing so may cause head, neck or spine injury.

### Installing the headrest

- 1 Recline the seat backrest to secure necessary space for installing the headrest safely.
- 2 Insert the headrest into the groove of the seat backrest.
- 3 With the Lock button (1) pressed in the arrow direction, pull down the headrest to the desired position.
- 4 Return the seat backrest to its original position.

### Adjusting the power seat\*

#### Front and rear position adjustment (driver seat/front passenger seat)

Set the seat to the desired position by pulling or pushing the front and rear position adjustment lever.



#### Adjusting the height (driver seat/front passenger seat)

Set the desired height by raising or lowering the height adjustment lever.



### Adjusting the cushion angle (driver seat/ front passenger seat)

Set the desired angle by raising or lowering the cushion angle adjustment lever.



### Adjusting the backrest angle (driver seat/ front passenger seat)

Set the desired angle by pulling or pushing the backrest angle adjustment lever.



#### Warning

- Adjust the seat backrest to be upright as possible to maintain a comfortable position. Reclining the seat backrest excessively may cause the occupant to slip down below the seat belt in the event of a vehicle collision or sudden stopping. In such case, the occupant cannot be protected by the seat belt and the air bag, so the occupant may receive a serious injury or lose his/her life.

### Adjusting the lumbar support (driver seat)

Set the lumbar support to the desired position by pressing the Lumbar support adjustment button.

- When you press the Forward/Backward adjustment button (1 / 2), the lumbar support is extended or retracted.



**Warning**

- Never adjust the seat while driving. If the seat moves suddenly, it may lead to a dangerous situation.
- After adjusting the seat, check that the seat is secured firmly.
- If there is an occupant in the rear seat, adjust the seat while paying attention to the safety of the occupant.
- If the power seat does not operate, drive the vehicle after checking and taking measures.

**Caution**

- Operating the power seat excessively may damage the electric devices. Use it only for adjusting the seat.
- Operating a number of seat adjustment switches at the same time may damage the motor. Be sure to finish using one function before using another function.
- The power seat operates even when the START/STOP switch is in the OFF status. However, caution should be taken that operating the power seat too frequently when the engine is turned off may cause depletion of the battery.
- If the height of the seat and headrest is high with the front seats pulled forward, be careful when folding the seat backrest forward. Failure to do so may cause the front seats, headrest, sun visor and other components to bump against each other, causing damage.
- If the power seat comes into contact with an object so that it does not move or operate, do not operate it forcibly. Operate it again after eliminating the cause. If there is abnormality, have your vehicle checked and serviced at a KG Mobility Corporation Authorized Service Center.

## Adjusting the seat manually

### Front and rear position adjustment (driver seat/front passenger seat)

With the front and rear position adjustment lever pulled up, set the seat to the desired position by pulling or pushing the seat.



## Adjusting the backrest angle (driver seat/ front passenger seat)

With the backrest angle control lever pulled up, move and set the backrest at the desired angle.



### Warning

- Adjust the seat backrest to be upright as possible to maintain a comfortable position. Reclining the seat backrest excessively may cause the occupant to slip down below the seat belt in the event of a vehicle collision or sudden stopping. In such case, the occupant cannot be protected by the seat belt and the air bag, so the occupant may receive a serious injury or lose his/her life.

## Adjusting the height (driver seat)

Set the desired height by raising or lowering the height adjustment lever.



## Rear seat

### Adjusting the height of the headrest

- To raise the headrest, hold and pull the headrest up.
- To lower the headrest, push the headrest down with the Lock button (1) pressed in the arrow direction.

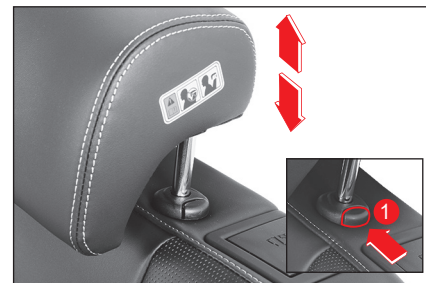

**Warning**



- Adjust the height of the head restraint so that the center of the head restraint is aligned with the occupant's eye level.
- Do not use the head restraint while it is lowered.
- When there is no occupant in the rear seats, the rear head restraints should be kept as low as possible as since they may obscure the rear view.

**Notice**

- Due to the occupant's physical condition, the center of the head restraint may not be able to align with the his or her eye level. In this case, set the height of the head restraint to the highest position for tall people and the lowest position for short people.

## Seatback reclining adjustment

You can adjust the reclining in step 1 or 2 while pulling the seatback release lever (1) at the side of the rear seat backrest.

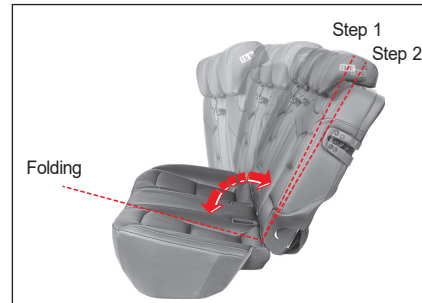

**Caution**

- When locking the rear seat backrest, make sure that the backrest unlock lever (1) clicks into the locked position so that the red label ("Unlocked" indicator) is not visible.





## Rear seat backrest folding

- 1 Insert the seat belt into the webbing guide to prevent the seat belt from being damaged.
- 2 Position the headrest to its lowest level.

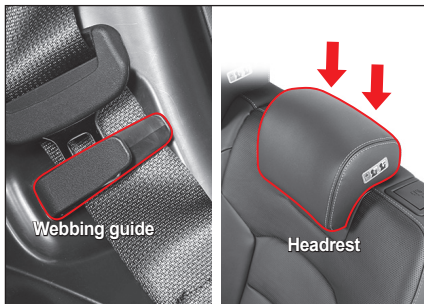

### ⚠ Caution

- When folding or unfolding the seat, it may hit and damage other components. To prevent such damage, lower the headrest of the seat to be folded to its lowest position and position the backrest of the seats in front of the folded seats.

- 3 Pull the rear seat backrest release lever (1).



- 4 Fold the backrest toward the front side of vehicle.



When returning the backrest to its original position, operate it in the reverse order.

### ⚠ Warning

- After returning the seat to its original position, gently rock the seat to make sure it is securely locked. If the seatback is not locked completely, it can be folded down unexpectedly.
- Be careful not to get your body parts to be caught in between the seats when folding the seat.
- Do not sit on the folded seat. You cannot be protected by the seat belt and other safety units and may be seriously injured in the event of an accident.
- When placing an article on top of the folded seat, secure the article firmly so that it won't move while driving. If the article moves, the driver and other passengers may get injured by the moving article. Also, a secondary accident may occur accordingly.

## Seat Ventilation & Heating

### Front seat ventilation and heating\*

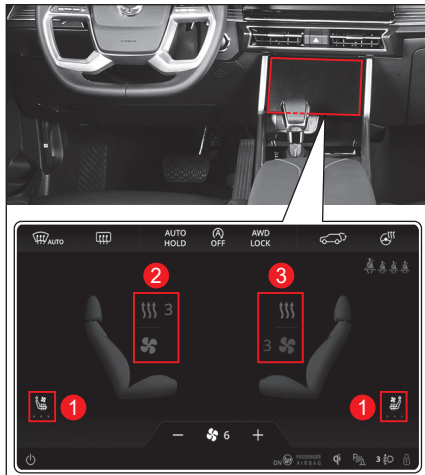

- 1 Ventilation and heating toggle switch
- 2 Driver's seat ventilation and heating switch
- 3 Front passenger's seat ventilation and heating switch

#### Notice

- If the switch is not operated for a certain period of time (approximately 8 seconds) on the front seat ventilation and heating pop-up screen, it will switch to the climate control screen.

### Front seat ventilation

Touch the ventilation and heating toggle switch (1) with the engine started and then touch the ventilation switch (2).

When the ventilation of the corresponding seat is activated, its level is displayed, and the level is indicated by the number of blue dots at the bottom of the toggle switch.

- OFF: Gray symbol shown
- ON:

Switch (2) (3): Blue symbol + Show corresponding levels

Switch (1): Number of blue dots corresponding to levels displayed



- Each time the ventilation switch is touched, ventilation operates in order of OFF → 3rd level → 2nd level → 1st level → OFF.

#### Warning

- Do not insert your hand under the seat cushion while the seat ventilation function is operating. Doing so may cause your hand to be hit and injured by the spinning ventilation fan.

#### Notice

- The seat ventilation function is not the cooling seat that blows out cold air from the air conditioner.
- Since the seat ventilation function draws in air from inside the vehicle and performs the ventilation function, it is efficient to use it together with the air conditioner.
- When you turn off the engine while the seat ventilation function is operating, the ventilation function also turns off. The seat ventilation function won't turn on even if you start the engine again.
- Ventilation is turned off by touching the ventilation switch or turning the engine off and on.

## Front seat heating\*

Touch the ventilation and heating toggle switch (1) with the engine started and then touch the heating switch (2,3).

When the heating of the corresponding seat is activated, its level is displayed, and the level is indicated by the number of red dots at the bottom of the toggle switch.

- OFF: Gray symbol shown
- ON:  
Switch (2,3): Red symbol + Show corresponding levels  
Switch (1): Number of red dots corresponding to levels displayed



- Each time the heating switch is touched, heating operates in order of OFF → 3rd level → 2nd level → 1st level → OFF.

## Smart front seat heating control

This function controls the heating operation status automatically while assisting you to drive safely in a proper temperature condition.

- If the status of level 3 is maintained for approximately 30 minutes, the status of the heating function is changed to level 2 automatically.
- After the status is changed to level 2
  - When you activate the heating function in level 3 again within 5 minutes, the status of level 3 is maintained for approximately 8 minutes and then the status is changed to level 2 automatically.
  - When you activate the heating function in level 3 again after 5 minutes later, the status of level 3 is maintained for approximately 30 minutes and then the status is changed to level 2 automatically.
- If the status of level 2 is maintained for approximately 60 minutes, the status of the heating function is changed to level 1 automatically.



### Warning

- Using seat heating excessively on the driver seat may cause drowsiness and interfere with safe driving.

### Notice

- The seat heating function is designed to stop its operation when the temperature rises to a certain level and resume its operation when the temperature falls below a certain level.
- When you turn off the engine while the seat heating function is operating, the heating function also turns off. The seat heating function won't turn on even if you start the engine again.
- Heating is turned off by touching the heating switch or turning the engine off and on.

## Rear seat heating\*

With the engine on, press the 1st row rear seat heating button.

The operation indicator (yellow) turns on and the heating function is activated in the relevant seat.



- Every time the heating button is pressed, the warmer is operated in the order of OFF → Level 2 → Level 1 → OFF.

### Rear seat heating smart control

- This function automatically controls the operation status of the warmer and helps the driver to operate the vehicle safely at an appropriate temperature.
- After operating for about 30 minutes in level 2, it automatically changes to level 1.
- After being changed to level 1
  - If you operate the warmer at level 2 again within 5 minutes, it will stay the level for about 8 minutes and change to level 1 automatically.
  - If you operate the warmer at level 2 again after 5 minutes, it will stay the level for about 30 minutes and change to level 1 automatically.

### Warning

- Caution should be taken that using the seat heating function excessively may cause a minor burn. Pay particular attention to an infant, a small child, an elderly, a disabled person, a person who took a drug that induces sleep, a drunk person, an over-worked person or a person with delicate skin.
- Caution should be taken that you may get a low temperature burn if your skin comes into contact with the heated seat for a long period of time.
- While using seat heating, do not place a blanket, cushion or sitting mat on the seat to prevent overheating.
- Using the seat heating excessively may cause overheating or fire. Be sure to check whether the seat heating is operating or not when getting in and out of the vehicle.
- If the seat becomes hotter continuously and out of control, turn off the seat heating function first. And, have your vehicle checked and serviced at a KG Mobility Corporation Authorized Service Center immediately.

### Notice

- The seat heating function is designed to stop its operation when the temperature rises to a certain level and resume its operation when the temperature falls below a certain level.
- When you turn off the engine while the seat heating function is operating, the heating function also turns off. The seat heating function won't turn on even if you start the engine again.

## Warnings and cautions related to the seats



### Warning

- Be sure to finish adjusting the seat before driving.
- Never adjust the seat while driving. If the seat moves suddenly, it may lead to a dangerous situation.
- Adjust the seat backrest to be upright as possible to maintain a comfortable position. Reclining the seat backrest excessively may cause the occupant to slip down below the seat belt in the event of a vehicle collision or sudden stopping. In such case, the occupant cannot be protected by the seat belt and the air bag, so the occupant may receive a serious injury or lose his/her life.
- Never drive the vehicle with the headrest separated. Doing so may cause head, neck or spine injury.
- If the power seat does not operate, drive the vehicle after checking and taking measures.
- Caution should be taken that using the seat heating function excessively may cause a minor burn. Pay particular attention to an infant, a small child, an elderly, a disabled person, a person who took a drug that induces sleep, a drunk person, an over-worked person or a person with delicate skin.



### Caution

- The power seat operates even when the START/STOP switch is in the OFF status. However, caution should be taken that operating the power seat too frequently when the engine is turned off may cause depletion of the battery.
- Operating a number of seat adjustment switches at the same time may damage the motor. Be sure to finish using one function before using another function.
- If the power seat comes into contact with an object so that it does not move or operate, do not operate it forcibly. Operate it again after eliminating the cause. If there is abnormality, have your vehicle checked and serviced at a KG Mobility Corporation Authorized Service Center.
- Do not place an object that can damage the seat upholstery on top of the seat.
- Do not use organic solvents such as thinner, benzene, alcohol or gasoline for cleaning the seat upholstery. Doing so may damage the surface of the upholstery.

## Window (power window)\*



- 1 Driver seat window button (AUTO)
- 2 Front passenger seat window button (AUTO)
- 3 Rear left window button
- 4 Rear right window button
- 5 Rear seat window lock button

### Notice

- To operate the window, the START/STOP switch should be in the ON status or the engine should be running.
- Even if the START/STOP switch is switched from the ON status to the ACC status or the OFF status, the Window button can be operated for approximately 30 seconds. However, the operation stops immediately when you open the front door.

### Opening the driver seat/front passenger seat window



- Press the Driver seat/Front passenger seat window button slightly. The Window opens only while the button is being pressed.
- Press the Driver seat/Front passenger seat window button to the end and release it. The window opens to the end automatically (auto down).
- When you slightly press or pull the Driver seat/Front passenger seat window button up while the window is opening, the window stops.

### Notice

- The vehicles with Auto Down have not fitted with the Auto Up and the window is closed only while the switch is being pulled.

### Closing the driver seat/front passenger seat window



- Pull the Driver seat/Front passenger seat window button up slightly. The window closes only while you are pulling the button.
- Pull the Driver seat/Front passenger seat window button up to the end and release it. The window closes to the end automatically (auto up).
- When you press or slightly pull the Driver seat/Front passenger seat window button up while the window is closing, the window stops.

## Driver seat window safety function

The driver seat window safety function controls the driver seat window equipped with the auto up function to move down slightly and stop without moving up from its position when it is recognized that a body part or an object is caught in it when the window is closing.



### Notice

- The window safety function is activated **only on the driver seat window equipped with the auto up function.**
- The safety function is **not activated for some section of the window that is closed lastly.**
- The window may get frozen during winter so that it may be misrecognized as a body part or an object being caught in it. In such case, close the window little by little by pulling the Window button slightly.
- When you do not release the Window button after pulling it up to the end, the window is closed to the end without stopping even if there is an obstacle in its moving path.

This function is intended to protect the driver from a crime such as robbery and injury.

## Opening/closing the rear seat window



The window only works while pressing or pulling the rear seat window button.

## Rear seat window lock function

This function locks the window so that it cannot be opened and closed from the rear seats.

Press the Rear seat window lock button.



### Warning

- **If a small child is seated in the rear seat, be sure to press the Rear seat window lock button to make the Window buttons inoperative. It can prevent an accident caused by the child's mischief.**

## What is wind buffeting?

Wind buffeting is the phenomenon when you feel pressure upon your ears or hear some noises such as the sound of a helicopter when you drive the vehicle with a rear seat window or the sunroof opened to a certain position.

This phenomenon occurs when air flows in through the rear seat window or the sunroof, creating resonance.

If you adjust the open space of the rear seat window or the sunroof when the wind buffeting occurs, such phenomenon disappears or is reduced.



### Warning

- **While driving or stopping, do not hold a part of your body such as your hand or head out of the window. You may get injured by a passing vehicle or an outside obstacle.**
- **Be careful not to get a part of your body such as your hand or head to be caught in the window when operating the window.**



### Caution

- **Operating a number of Window buttons at the same time may damage the fuse that is the over-current protective device or the window system.**
- **Operating the Window buttons on the driver seat door and a different door in the opposite direction at the same time may damage the window system.**



The sunroof is a secondary window installed on the vehicle roof for supporting pleasant driving such as ventilation and lighting in the vehicle.

The sunroof window can be slide opened and closed and it also operates in a tilting way to lift the rear section of the sunroof up slightly.

The sunroof cover can be opened and closed by hand.

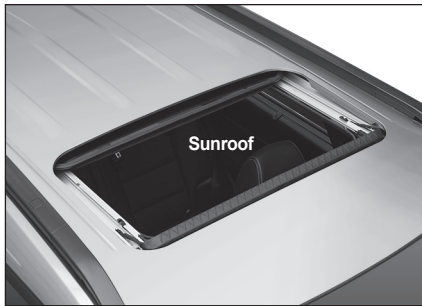

## Warning

- While driving or stopping, do not hold a part of your body such as your hand or head out of the sunroof. You may get injured by a passing vehicle or an outside obstacle.

## Caution

- The sunroof operates even when the START/STOP switch is in the ON status. However, caution should be taken that using the sunroof excessively while the engine is not running may cause depletion of the battery.
- After finishing the sunroof operation, release the Control button. Pressing the Control button continuously may cause a malfunction.
- If the sunroof is opened completely, the wind buffeting may become intensified. In such case, adjust the open space in the sunroof.
- If the sunroof operation part is frozen during winter, operate it after the frozen part melts completely.
- Remove dust and foreign materials from the rubber part around the sunroof window periodically. If dust and foreign materials are present, noise may occur when the sunroof operates and it may cause a malfunction.

## Notice

- To operate the sunroof, the START/STOP switch should be in the ON status or the engine should be running.

## Opening the sunroof

### Opening automatically

Press the sunroof open button briefly. The sunroof opens automatically.

The rear part (6cm) of the sunroof will not open.

To open the sunroof fully, press the sunroof open button again.



#### Notice

- Operating the switch while the sunroof is opening stops the sunroof operation.

### Opening manually

Press and hold the sunroof open button. The sunroof will only open while the open button is pressed.

To open the sunroof fully, you must keep the open button pressed.

#### What is wind buffeting?

Wind buffeting is the phenomenon when you feel pressure upon your ears or hear some noises such as the sound of a helicopter you when you drive the vehicle with a rear seat window or the sunroof opened to a certain position.

This phenomenon occurs when air flows in through the rear seat window or the sunroof, creating resonance.

If you adjust the open space of the rear seat window or the sunroof when the wind buffeting occurs, such phenomenon disappears or is reduced.

## Closing the sunroof

### Closing automatically

Press the sunroof close button briefly. The sunroof closes automatically.



#### Notice

- Operating the switch while the sunroof is closing stops the sunroof operation.

### Closing manually

Press and hold the sunroof close button. The sunroof will be closed only while you are pressing the close button.

In order to close the sunroof fully, you have to keep pressing the close button.

## Tilting the sunroof up/down



### Tilting up (opening the rear section)

With the sunroof closed, pull the Sunroof button. The rear section of the sunroof will open.

### Tilting down (closing the rear section)

With the rear section of the sunroof opened, press the Sunroof button. At this time, the sunroof closes only while the button is being pressed.

To close the sunroof completely, you should press and hold the button.

## Sunroof open warning

When you place the START/STOP switch in the ACC or OFF position and open the driver seat door with the sunroof opened, the sunroof open warning buzzer will sound.

When you close the door, the warning buzzer will be turned off.

When the sunroof open warning buzzer sounds, leave the vehicle after closing the sunroof completely.



#### Caution

- When leaving the vehicle, check if the sunroof is closed completely. Leaving the vehicle with the sunroof opened may cause a robbery case through the sunroof. Also, the inside of the vehicle may get wet when it rains or snows.

## Sunroof safety function

The sunroof safety function controls the sunroof to open without closing from its position for safety when it is recognized that a body part or an object is caught in it when the sunroof is closing automatically.

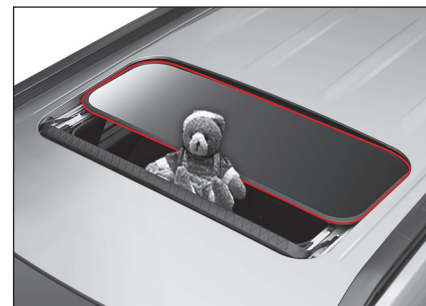

#### Caution

- The sunroof safety function is not activated for the last section of the sunroof to be closed.
- The sunroof safety function is just an auxiliary system and it is no substitute for the driver's attention. Always exercise caution since it may not operate according to an electrical device or other situations.

## Resetting the sunroof

### Cases requiring the resetting of the sunroof

- When the battery is depleted or the power supply is suspended with the sunroof opened
- When the sunroof does not open or close completely by operating the button once
- When the sunroof is tilted without stop after it is closed in the sliding method
- When the moving distance has decreased significantly when sliding or tilting the sunroof
- If the sunroof does not operate or operates abnormally when the Sunroof button is pressed

### Resetting

With the sunroof tilted up (opening the rear section), pull the Sunroof button continuously for approximately 20 seconds.

- A clicking sound occurs once approximately 5 seconds later and once again approximately 20 seconds later after pulling the Sunroof button. The sunroof resets along with the second clicking sound.
- When you press the Sunroof button slightly after resetting, the sunroof opens and closes again automatically.



#### Caution

- **If the sunroof does not operate normally after resetting the sunroof, have your sunroof checked and serviced at a KG Mobility Corporation Authorized Service Center.**

The tailgate is a unit that increases the convenience in loading or unloading an article from the vehicle.

The power tailgate allows the user to open and close the tailgate using a simple button operation.

Also, the smart tailgate opens the tailgate automatically when a user approaches to the detection area at the back of the tailgate.



## Warning

- Do not disassemble the manual and power tailgate support bars. It is composed of the high pressure devices, which may cause injuries.
- Do not apply heat the manual and power tailgate support bars. It may be damaged by heat and cause injuries.
- Do not dismantle the tailgate's gas lifter. It is composed of the high pressure devices, which may cause injuries.
- Do not heat the tailgate's gas lifter. It may be damaged by heat and cause injuries.
- In order to replace or dispose of the gas lifter, please visit our nearest KG Mobility Authorized Service Center.

## Manual tailgate

### Opening

- 1 Press the Tailgate open button on the inner side of the tailgate door handle while carrying the smart key.

The tailgate will be unlocked.

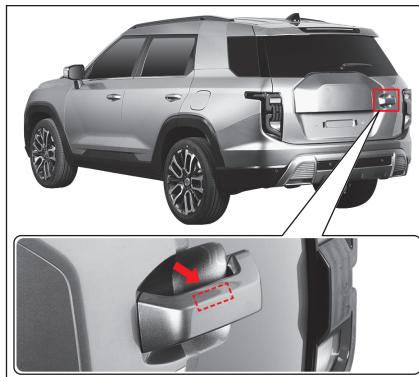

- 2 Lift the tailgate up.

### Notice

- The range that the tailgate can recognize the smart key is within approximately 1 m.
- When you press the Tailgate open button, only the tailgate is unlocked. The door, engine hood and other devices remain locked.

### Closing

- 1 Hold the inner handle of the tailgate and pull the tailgate down.



- 2 Close the tailgate by pushing it slightly.



### Caution

- When the tailgate is opened and closed with the theft monitoring canceled, the mode is not switched to the theft monitoring mode automatically. Be sure to switch the mode to the theft monitoring mode by pressing the Door lock button on the smart key.

### Notice

- When the tailgate is opened and closed in the theft monitoring mode, the mode returns to the theft monitoring mode automatically. At this time, the hazard warning lamp blinks twice and the warning buzzer sounds once.

## Power tailgate\*

The power tailgate is a unit that allows the user to open and close the tailgate using a simple button operation.

The power tailgate operates when the gear shift lever is in P (Parking) position with the START/STOP switch in the ON status or in all positions of the gear shift lever when the engine is turned off.

### Notice

- If the vehicle speed is 3km/h or faster with the START/STOP switch in the ON status, the tailgate cannot be opened automatically.

## Open/Close Tailgate With Interior Switch



- Touch and hold the interior switch for the tailgate.

After the hazard warning lamp blinks twice and the warning buzzer sounds twice, the tailgate opens or closes.

The tailgate opens if it is closed or it closes if it is opened.

### Notice

- When you press the Tailgate button while the power tailgate is opening or closing, the tailgate stops on that position.
- The interior switch for the power tailgate remains visible even when the buttonless integrated control panel is switched off.

## Opening/closing with the smart key



- Press and hold the Tailgate button on the smart key. After the hazard warning lamp blinks twice and the warning buzzer sounds twice, the tailgate opens or closes. The tailgate opens if it is closed or it closes if it is open.

### Notice

- **When you press the Tailgate button while the power tailgate is opening or closing, the tailgate stops on that position.**

## Opening/closing with the button on the tailgate

- Press the Tailgate outside button while carrying the smart key. After the hazard warning lamp blinks twice and the warning buzzer sounds twice, the tailgate opens.



### Notice

- The range that the tailgate can recognize the smart key is within approximately 1 m.
- When you press the Tailgate outside button, only the tailgate is unlocked. The door, engine hood and other devices remain locked.

Press the Tailgate inside button with the tailgate opened.

After the hazard warning lamp blinks twice and the warning buzzer sounds twice, the tailgate closes.



## Anti-pinch protection function

The anti-pinch protection function controls the tailgate to stop at that position or open completely for safety when a strong impact is received from the outside or a certain level of force is detected while the power tailgate is opening or closing.



### Warning

- **The anti-pinch protection function may not operate if the resistance detected by the power tailgate is smaller than a certain level of force or the tailgate is in the position that it is almost closed.**
- **Do not place a part of your body or an article on the moving path of the tailgate on purpose in order to check the anti-pinch protection function during the power tailgate operation. Doing so may cause serious injury or article and device damage.**



### Caution

- **If the anti-pinch protection function operates repeatedly for a number of times, close the tailgate manually and operate it again. If there is an abnormality, have your vehicle checked and serviced at a KG Mobility Corporation Authorized Service Center.**

## Resetting the opening height

The maximum opening height of the power tailgate can be reset in accordance with the user's physical condition or other conditions such as the parking space.

- 1** Open the tailgate manually and adjust it to a desired height.
- 2** Press the Power tailgate inside button for 3 seconds or more.  
When the resetting is completed, a beep sound occurs.
- 3** Close the tailgate completely by pressing the Power tailgate inside button.

When the opening height is reseted, press the Power tailgate outside button to see if the tailgate opens to the set position.

## Resetting the power tailgate

If the power supply is reconnected after the battery is fully depleted or the power supply is disconnected or if the power tailgate does not function normally, reset the power tailgate.

- 1** Park the vehicle on a flat ground and shift the gear shift lever to the P (Parking) position.
- 2** With the Tailgate inside button pressed, press and hold the Outside button for 3 seconds or more.  
When the resetting is completed, a beep sound occurs.
- 3** Close the tailgate completely by hand.

When the resetting is completed, check that the power tailgate opens and closes normally.





### Caution

- Do not operate the power tailgate in any of the following cases since it may malfunction.
  - When one wheel of the vehicle is lifted up for vehicle check or tire replacement
  - When one wheel of the vehicle is in the air unevenly on a sloping road or paving blocks
  - When the vehicle is parked or stopped on a slope or an uneven surface
- The power tailgate operates even when the START/STOP switch is in the OFF status. However, caution should be taken that operating the power tailgate excessively with the START/STOP switch turned off may cause depletion of the battery.
- When you operate the power tailgate for 5 times or more consecutively, the warning buzzer sounds 3 times and the power tailgate stops in order to prevent the drive motor from being overheated. In such case, stop the operation of the power tailgate for 1 minute or longer and then operate the power tailgate again.

- Do not operate the power tailgate manually if possible.
- If it is necessary to operate the power tailgate manually since it does not operate normally, do not apply excessive force. Doing so may damage the power tailgate unit.
- Do not apply excessive force to the tailgate while the power tailgate is operating. Doing so may damage the power tailgate.
- If you close the tailgate immediately after opening it, the tailgate may not be closed. This is a normal operation. Close the tailgate after a short time interval.
- Do not attach a heavy object to the power tailgate. Doing so may damage the power tailgate.
- Do not modify or repair the power tailgate and relevant components arbitrarily.

## Smart tailgate\*

The smart tailgate is a function that opens the tailgate automatically when a user carrying the smart key approaches the detection area at the back of the vehicle. This is particularly convenient when you are carrying packages in both hands.

### Activating/deactivating the smart tailgate

- You may enable this function at **User setting** → **Door / Tailgate** → **Smart Tailgate** under  (user settings) in the instrument cluster.

#### Notice

- You must enable the power tailgate to enable the smart tailgate.

## Opening the smart tailgate

### Operating condition

- The engine should be turned off and all doors and the tailgate should be in locked status (theft monitoring mode).
- You should stay in an area within approximately 1 m from the smart tailgate sensor at the back of the vehicle for approximately 3 seconds or more while carrying the smart key.

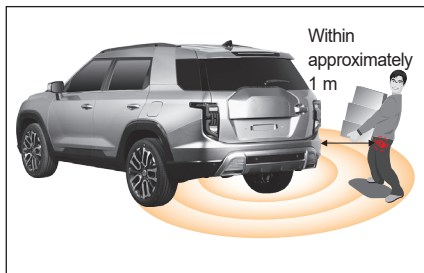

### Operation step

The tailgate opens automatically in the following steps after the smart key is detected.



#### • Step 1

The hazard warning lamp and the warning buzzer sound three times at an interval of 1 second (beep~ beep~ beep~)

#### • Step 2

The hazard warning lamp and the warning buzzer sound three times (beep beep beep)

#### • Step 3

The hazard warning lamp and the warning buzzer sound two times (beep beep)

Next, the tailgate opens.

## Stopping the smart tailgate function

- Press any button on the smart key.
- Or, get out of the detection area of the smart tailgate.



- The smart tailgate begins operating when 30 seconds have passed after entering the theft monitoring mode. This is for preventing the smart tailgate from malfunctioning.
- In any of the following cases, the smart tailgate operation may be delayed or the operating range may change due to frequency interference.
  - When you are in or near a facility where a strong radio frequency is emitted including a police station, government office, broadcasting station, military unit, transmitting tower, airport, harbor, etc.
  - When you carry the smart key along with a mobile phone or a radio set, etc.
- In any of the following cases, the detection range of the smart key may vary, affecting the operation range of the smart tailgate.
  - When one wheel of the vehicle is lifted up for checking the vehicle or replacing tires
  - When the vehicle is parked or stopped on a sloping road or an uneven surface

- Do not stay in the detection area of the smart tailgate unnecessarily while carrying the smart key.
- Familiarize yourself with how to deactivate and stop the smart tailgate function in preparation for an emergency as well as various other situations.
- Be sure to deactivate the smart tailgate function when you wash your vehicle. Failure to do so may cause the tailgate to open automatically, causing a personal injury or damage to the vehicle and other facilities.

## Opening the tailgate in the event of emergency

You can open the tailgate using the unlock lever in the tailgate in the event of depletion of the battery, failure of the tailgate devices or other emergency situations.

- 1 Unfold the mechanical key of the smart key or REKES key.

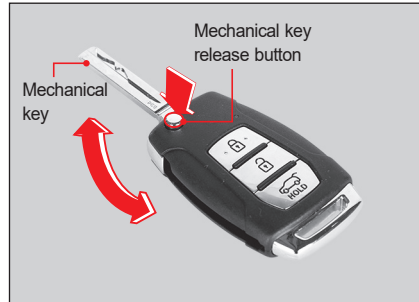

- 2 Insert the mechanical key into the unlock lever hole (1) at the bottom center.



- 3 Press the mechanical key in the direction of the arrow. It unlocks the tailgate.



- 4 Push open the tailgate.



### Warning

- Only use the tailgate unlock lever in the event of emergency.
- Do not allow children to play in the luggage compartment. If the tailgate unlock lever operates, opening the tailgate suddenly while driving, a serious accident may occur.



### Caution

- Familiarize yourself with the position of the tailgate unlock lever and how to use it in preparation for an emergency.



### Warning

- Avoid driving the vehicle with the tailgate open.
  - Exhaust gas may flow into indoors, resulting in gas poisoning.
  - An article from the inside of the vehicle may fall out, causing an accident.
  - The tailgate or other vehicle parts may get damaged.
- Driving the vehicle at a speed of 4km/h or faster with the tailgate open, the tailgate open warning light turns on and the warning buzzer sounds 10 times. Move the vehicle to a safe place immediately and close the tailgate firmly.
- Open or close the tailgate after confirming the safety inside and outside of the vehicle. In particular, be careful not to get a part of an indoor occupant or a near-by person's body caught.
- Be careful not to allow a child to operate the power tailgate or smart tailgate by accident while carrying the smart key. Failure to do so may cause damage to a near-by person, article or vehicle, etc.

- Do not open the tailgate after parking or stopping the vehicle on a sloping road. Doing so may cause an article loaded in the vehicle to fall out, causing injury to a user.
- When you close the tailgate, the tailgate may close suddenly due to the weight of the tailgate and other external factors. Be cautious for preventing injury when closing the tailgate.

# Engine hood

## Opening the engine hood

- 1 Pull the engine hood open lever (1) located at the bottom left side of the driver seat.

The engine hood will be opened slightly.



- 2 Lift the engine hood slightly to pull the engine hood latch lever (2) up and lift up the engine hood completely.

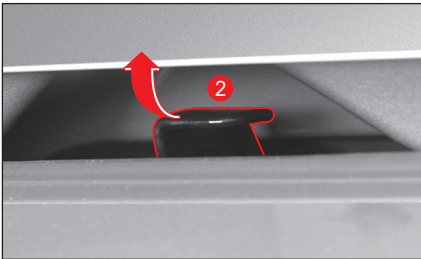

- 3 Lift the engine hood up.  
When you lift engine hood half way, it will open to the end automatically.

## Closing the engine hood

### Checking before closing the engine hood

- Make sure that all inlet caps in the engine room are closed properly.
- Check that no unnecessary items including gloves and tools are left in the engine room.

### Closing the engine hood

Pull the engine hood down and close it by pressing it down.

#### Caution

- If the engine hood is lifted slightly while it is closed, open the engine hood again and close it by pushing it with stronger force.
- The side garnish (A) mounted on the engine hood is a component for design purposes. Do not use side garnish for hanging ropes, hoops, etc. This may lead to damage to the side garnish and damage to the vehicle.



#### Warning

- Open the engine hood after turning off the engine. However, if you need to check and carry out services with the engine on, pay particular attention not to be injured by the operating devices in the engine room.
- Check the engine hood in a place where no wind blows. You may get injured if the engine hood is closed by wind.
- Be careful not to get any of your body parts such as fingers caught when closing the engine hood.
- Confirm that the engine hood is closed completely before driving. If you drive the vehicle with the engine hood open, the vehicle may get damaged and it may block the driver's vision, causing a serious accident.
- Do not disassemble the hood gas lifter. It is composed of the high pressure devices, which may cause injuries.
- Do not apply heat the hood gas lifter. It may be damaged by heat and cause injuries.
- When Replacing and disposing of gas lifter, have your vehicle serviced at a KG Mobility Corporation Authorized Service Center.

## Fuel inlet

### Opening the fuel inlet

The fuel inlet cover can be opened only when all doors are unlocked.

- 1 Shift the gear shift lever to the P (Parking) position.  
(Place the shift lever in the N (Neutral) position for the vehicles with the manual transmission.)
- 2 Apply the parking brake.
- 3 Be sure to turn off the engine.
- 4 Push the center edge of the fuel inlet cover in the arrow direction.

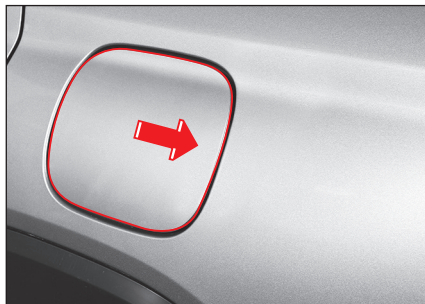

#### Caution

- If the fuel inlet cover is frozen during winter, do not open it forcibly. Open it by gently tapping on the edge of the cover.

- 5 Open the fuel inlet cover completely by pulling it in the arrow direction.



- 6 Open the fuel inlet cap by turning it counterclockwise.



- 7 Hang the fuel inlet cap on the holder mounted inside the fuel inlet cover.



#### Warning

- Separate the fuel inlet cap carefully since pressure may be applied to the fuel. If you hear a sound of fuel leakage or deflation, wait until such sound stops and then separate the cap again. Failure to do so may cause fuel to emit, causing a serious injury.
- When you touch the fuel inlet cap or the gas pump, contact a metal part that is far away from the fuel inlet with bare hands first to remove static electricity. Failure to do so may cause a fire due to static electricity.

## Closing the fuel inlet

- 1 Close the fuel inlet cap by turning it clockwise until a clicking sound occurs.
- 2 Close the fuel inlet cover by pushing the center edge of the fuel inlet cover.

### Information - Fuel label

#### • PETROL TYPE OF FUEL



The shape for a petrol- type fuel is a circle ("E" stands for specific bio-components present in petrol)

### Warning

- Be sure to refuel after stopping the engine. Failure to do so may cause vaporized fuel to ignite due to a spark generated from an electrical device when starting the engine, causing a serious fire.
- Keep any Inflammables such as a lighted cigarette or a lighter away during refueling. Failure to do so may cause a serious fire.
- Do not take an action that may generate static electricity such as getting in and out of the vehicle during refueling. Doing so may cause a serious fire due to static electricity.
- If it is necessary to refuel using a portable container, refuel with the container placed on the ground. Refueling with the container placed on top of or inside the vehicle may cause a serious fire due to static electricity.
- Be sure to refuel after checking the type of the fuel used. If you misfuel a vehicle using diesel or gasoline, the fuel system and other vehicle systems may be affected, damaging the vehicle significantly.
- Do not use fuel containing a lot of moisture, improper fuel or additives. Doing so may damage the fuel system and the exhaust gas system of the vehicle significantly.

- Refuel only until the pump nozzle of the fuel supply gun stops automatically. Filling the fuel tank excessively may cause fuel to overflow, causing a fire and damaging the vehicle body.
- Do not use a mobile phone near a gas station. Doing so may cause a fire due to an electromagnetic wave or current of the mobile phone.
- If a fire occurs while refueling, evacuate to a place far from the vehicle immediately. Then, take measures such as the reporting the fire.

### Caution

- Be careful not to allow the fuel to contact the vehicle body as it can damage the painted surface.
- Be sure to use a genuine fuel inlet cap when it is necessary to replace it.

## Outdoor lights/lamps

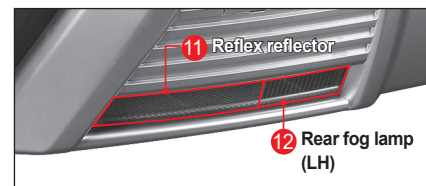
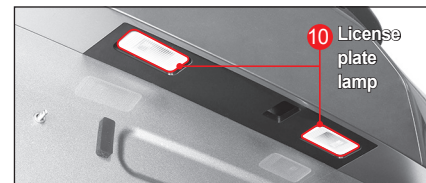
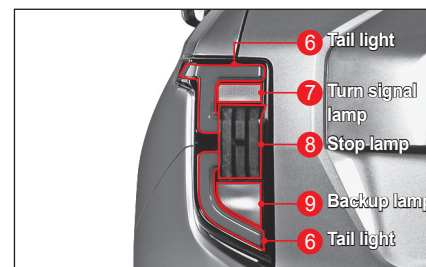
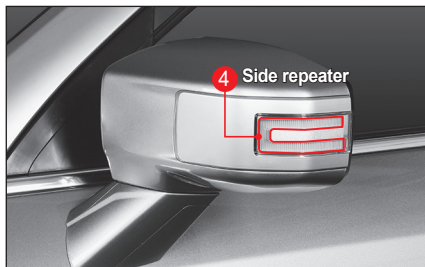
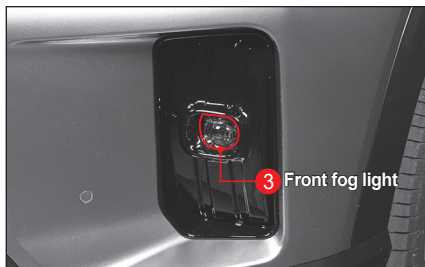
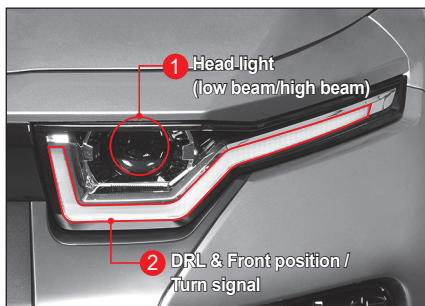



## Light switch

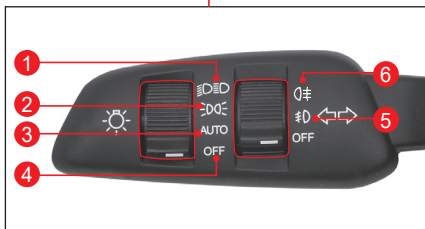

- 1 Head light
- 2 Tail light
- 3 Auto light function
- 4 Turning off all lights
- 5 Front fog light
- 6 Rear fog light

### Turning on the head light

The head light turns on along with the sidelight, tail light, license plate lamp, front fog light (in the ON status) and other interior lights.

### Turning on the tail light

The tail light turns on along with the sidelight, license plate lamp, front fog light (in the ON status) and other interior lights.

### **AUTO** Activating the auto light function\*

The head light and the tail light turn on or off automatically according to the amount of sunshine received by the auto light sensor.

### Turning on Smart High Beam Assist (SHB)

Pushing the Light switch in the direction of instrument cluster with the Light switch in the AUTO position activates the SHB.

 Refer to "Smart High Beam (SHB)\*" (p.3-41)

### **OFF** Turning off all lights

All lights turn off.

#### Notice

- For the vehicles without the auto light and fog lamp, the light switch has no corresponding function.

### Turning on the front fog light\*

When you place the Light switch in the  (front fog light) position with the head light or the tail light on, the front fog light turns on.

### Turning on the rear fog light\*

With the headlights turned on, if you rotate the switch in  position, rear fog lights turn on and the switch returns back in front fog light position. Rear and front fog lights turn on simultaneously. Turning it again will turn off the rear fog lamp.

### **OFF** Turning off the fog light\*

The fog light turns off.

### Turning on/off the left/right turn signal



- When you push the Light switch down (1), the left turn signal blinks. At this time, the turn signal on the instrument cluster also blinks.
- When you push the Light switch up (2), the right turn signal blinks. At this time, the turn signal on the instrument cluster also blinks.

## Turning on/off the high beam



- When you push the Light switch in the direction of instrument cluster and release it with the low beam on, the high beam turns on. At this time, the high beam indicator on the instrument cluster also turns on.
- When you pull the Light switch in the driver's direction and release it with the high beam on, the high beam turns off.

### Warning

- **Do not turn on the high beam if there is an oncoming vehicle or a vehicle at the front. The high beam may block the other drivers' vision, causing an accident.**

## Turning on the high beam and low beam at the same time (passing light)



The high beam and the low beam turn on at the same time while pulling the Light switch in the driver's direction.

### Notice

- **This function operates regardless of the position of the Light switch.**

## Hazard warning lamp

The hazard warning lamp is used to give warning to other vehicles in the event of emergency for preventing an accident.

- When you press the Hazard warning lamp switch, all turn signals blink.
- When you press the Hazard warning lamp switch again, the hazard warning lamp turns off.

 Refer to "Emergency Stop Signal (ESS)" (p.4-138)

### Caution

- **Do not operate the hazard warning lamp for a long period of time with the engine off. Doing so may cause confusion to other vehicle drivers as well as depletion of the battery.**

### Notice

- **The hazard warning lamp operates regardless of the status of the START/ STOP switch**
- **While the hazard warning lamp is operating, the turn signal does not operate independently.**

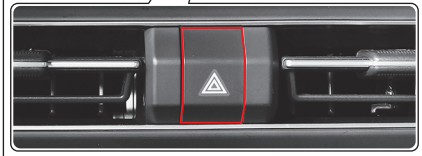
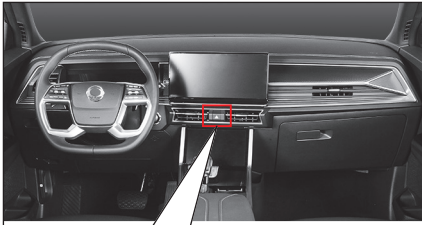

## Adjusting the angle of the head light

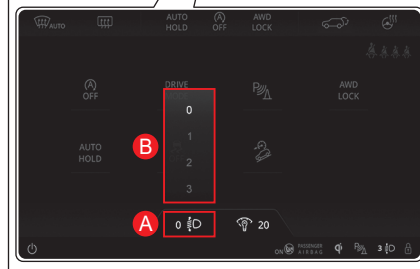
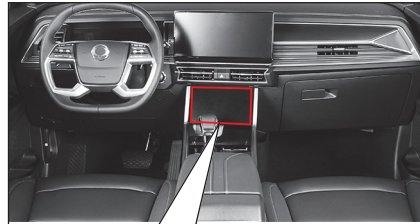

The front and rear slope of the vehicle may vary depending on the number of occupants, weight and center of gravity of luggage.

In such case, you can adjust the angle of the head light to secure proper vision at night and not to obstruct an oncoming vehicle or a vehicle at the front with a strong light from the head light.



Touch the headlamp aiming switch (A) lightly and touch the angle for each step to secure proper night vision and make sure that the driver of the facing or leading vehicle is not disturbed by the strong light of the headlights on your vehicle.

## Angle adjustment levels of the head light

The angle of the head light can be adjusted in 4 levels (Levels 0~3) according to the front and rear slope of the vehicle.

- When the vehicle is tilted forward Lower the head light angle adjustment dial (Level 0 direction). The head light is adjusted to face up.
- When the vehicle is tilted backward Raise the head light angle adjustment dial (Level 3 direction). The head light is adjusted to face down.

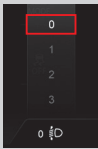
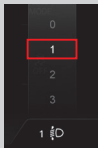
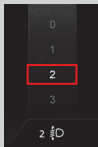
## Angle adjustment standard for the head light

	Number of occupants and loading condition
<b>Level 0</b> 	<ul style="list-style-type: none"> <li>1~2 occupants (normal driving)</li> </ul>
<b>Level 1</b> 	<ul style="list-style-type: none"> <li>1~2 occupants and luggage (approximately 90 kg)</li> <li>4~5 occupants</li> </ul>
<b>Level 2</b> 	<ul style="list-style-type: none"> <li>4~5 occupants and luggage (approximately 100 kg)</li> </ul>
<b>Level 3</b> 	<ul style="list-style-type: none"> <li>1 occupant and luggage (approximately 400 kg)</li> </ul>

### Warning

- Drive the vehicle after adjusting the angle of the head light according to the number of occupants, weight and center of gravity of luggage. Failure to do so may cause an accident.
  - Never drive the vehicle in any of the following cases that go beyond the angle adjustment standard for the head light.
    - Driving the vehicle with level 3 under the condition of level 0 (the angle of the head light is lowered): It takes longer for the driver to recognize an emergency situation on the road ahead if it occurs.
    - Driving the vehicle with level 0 under the condition of level 3 (the angle of the head light is raised): It obstructs the vision of the driver in an oncoming vehicle or a vehicle at the front.
- In such case, it may obstruct safe driving, causing a serious accident.

## Daytime Running Light (DRL)\*

The DRL also turns on automatically during daytime, allowing you to recognize a vehicle easily.



### In case the DRL turns on

- If the switch of the tail light, front fog light and head light is not operated with the START/STOP switch in the ON (irrelevant to whether the engine is started or not) status

### Notice

- When the DRL turns on, the tail light also turns on at the same time.
- The same lamp is used for the DRL and the tail light, but the DRL is more bright.

### In case the DRL turns off

- When the START/STOP switch is in ACC or OFF status
- When you turn on the head light or the head light is turned on by the auto light function
- When you turn on the front fog light
- When parking brake (EPB) applied at the vehicle speed of 3 km/h or less (AUTO HOLD switch turned off)
- When the hazard warning indicator is activated
- When the left / right turn signal indicator is activated

### Smart High Beam (SHB)\*

The SHB is the function to control the high beam not to obstruct the vision of a driver in an oncoming vehicle or a vehicle at the front with a strong light from the high beam.

The SHB detects the situation through the sensor at the top of the vehicle windshield (front camera module) and turns on or off the high beam automatically.

### Setting the SHB

- 1 Place the Light switch in the AUTO position.



- 2 Push the Light switch in the direction of instrument cluster and release it.



- When the SHB function is activated, the SHB indicator turns on.



SHB indicator

### In case the high beam turns on

All the following conditions are set with the SHB activated, the high beam turns on.

- When the vehicle speed is 35 km/h or faster
- When the surrounding area is dark that it is detected as night
- When an oncoming vehicle and a vehicle at the front are not detected

When the light beam turns on automatically, the SHB indicator turns on along with the high beam indicator.



SHB indicator



High beam indicator

### In case the high beam turns off

The high beam turns off in any of the following cases.

- When the head light of an oncoming vehicle (including a bicycle and a motor cycle) is detected
- When the tail light of a vehicle (including a bicycle and a motor cycle) at the front is detected
- When it is bright in the surrounding area due to streetlights or other lighting sources in the surrounding roadside.
- When the light source of a tunnel is detected
- When the Light switch is not in the AUTO position
- When the SHB function is deactivated
- When the vehicle speed is less than 25 km/h

#### Notice

- **When the high beam turns off and then turns on again automatically, there may be a delay time for few seconds.**

### Operating the Light switch

The detailed operation of the Light switch with the SHB set and activated is as follows.

- When you push the Light switch in the direction of the instrument cluster with the SHB set and operating, the high beam turns on and the SHB setting is canceled.
- When you pull the Light switch in the driver's direction with the SHB set, the high beam turns on and the SHB setting is maintained only while pulling the Light switch.
- When you pull the Light switch in the driver's direction while the SHB is operating, the high beam turns off and the SHB setting is canceled.
- When you place the Light switch in positions other than the AUTO position, the SHB setting is canceled.



### Caution

In any of the following cases, the SHB may not operate normally.

- When the vehicle windshield is damaged or contaminated by dust, mist, fog, sticker, snow, etc
- When the lamp of an oncoming vehicle or a vehicle at the front is damaged
- When an oncoming vehicle or a vehicle at the front is out of your front sight
- When an oncoming vehicle and a vehicle at the front are recognized only partially in an intersection or a winding road
- When there is a light source similar to a vehicle lamp or a reflector at the front
- When an illuminator or a reflector is installed in a construction section, etc.

## AUTO Approach



AUTO approach (outside rearview mirror unfolded) is activated when you are approaching within 1 m of the vehicle while carrying the smart key in theft deterrent mode.

### Notice

- You may enable this function at **User setting** → **Convenience** → **Approach Welcome or Auto Approach Welcome** under  (user settings) in the instrument cluster.

## In case the auto approach lamp turns off

In any of the following cases, the auto approach lamp turns off.

- When approximately 30 seconds have passed after the auto approach lamp turns on
- When the START/STOP switch is in the ON position
- When the vehicle enters the theft monitoring mode
- When the smart door auto lock is activated

### Notice

- **The auto approach lamp operates up to 2 times within 10 minutes.**
- You may enable this function at **User setting** → **Convenience** → **Approach Welcome or Auto Approach Welcome** under  (user settings) in the instrument cluster.

## Coming home/living home light

The coming home/living home light is the function that turns on the head light automatically when the vehicle arrives or leaves in dark environments, increasing the safety and convenience.

### Setting the coming home/living home light

- Select **User setting** → **Light** → **Coming home headlamp or / Living home headlamp set time** (time for which the light comes on) under  (user settings) in the instrument cluster.  
(Disable, 10 sec, 20 sec and 30 sec)

## Operating the coming home light

- When you turn off the engine with the head light (low beam) on, the head light (low beam) stays on for the set duration.
- When a certain amount of time has passed with all doors and the tailgate closed, the head light (low beam) turns off.

### Notice

- If you maintain the door or the tailgate opened within the set time after turning off the engine, the head light (low beam) turns off after 3 minutes.
- When you open and close the door or the tailgate within the set time after turning off the engine, the head light (low beam) stays on for the set time and then it turns off.
- When you place the Auto light and Head light (low beam) switches in the OFF position, the head light (low beam) turns off immediately.

## Operating the living home light

- When you cancel the theft monitoring mode by pressing the Door unlock button on the smart key or the Door handle switch, the head light (low beam) stays on for the set time.
- When the set time has passed, the head light (low beam) turns off.

### Notice

- When you press the Door lock button on the smart key with the living home light on, the head light (low beam) turns off and the vehicle enters the theft monitoring mode.
- When you place the START/STOP switch in the ON position with the living home light on, the head light (low beam) turns off immediately.



## Auto light function\*

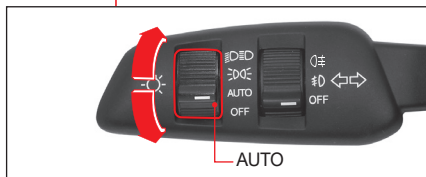

The auto light is the function that detects the amount of sunshine through the sensor and turns on or off the head light and the tail light automatically.

- The auto light function is activated when the Light switch is positioned in the AUTO position.

## Auto light sensor



The auto light sensor is integrated with the rain sensor.

### Caution

- When you shake or apply an impact to the auto light sensor, the auto light may malfunction.
- Do not wipe the auto light sensor installation part with cleaning agents or wax, etc. The auto light function may malfunction.
- Attaching commercially available window coating or tinting products to the windshield may cause the auto light function to malfunction.
- If the vehicle vibrates significantly just as driving on a road with an uneven surface, the auto light function may malfunction.

- The time to turn on and off the light may vary depending on a change in the climate condition such as fog, snow and rain and surrounding environment.
- When you change the Light switch to the AUTO position or from the AUTO position to another position, the lights inside the vehicle, tail light and head light may blink momentarily. This is a normal phenomenon for recognizing the status of the auto light.
- When passing through a dark place such as a tunnel, do not depend on the auto light function and turn on the head light manually.
- Use the auto light function for the head light and the tail light limitedly only at the time of sunrise and sunset. In general, operate the head light and the tail light manually.
- Do not use the auto light function for the head light and the tail light on a gloomy day. Operate such lights manually.

## Interior lamp

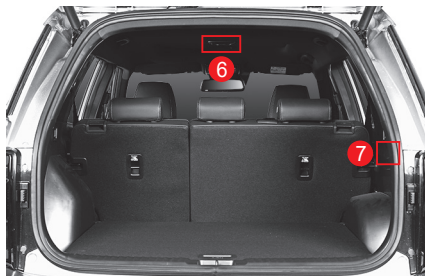
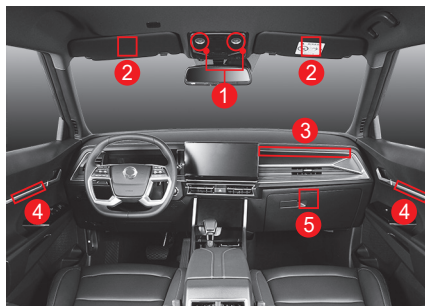
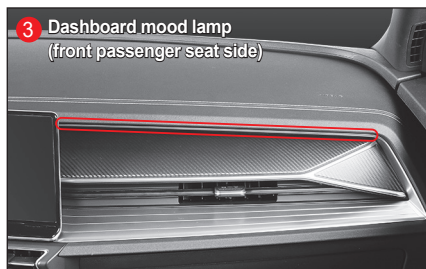
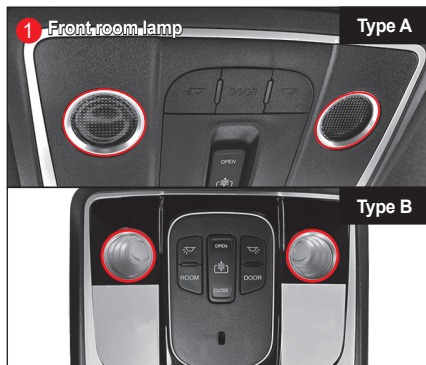

## Front room lamp (overhead console)

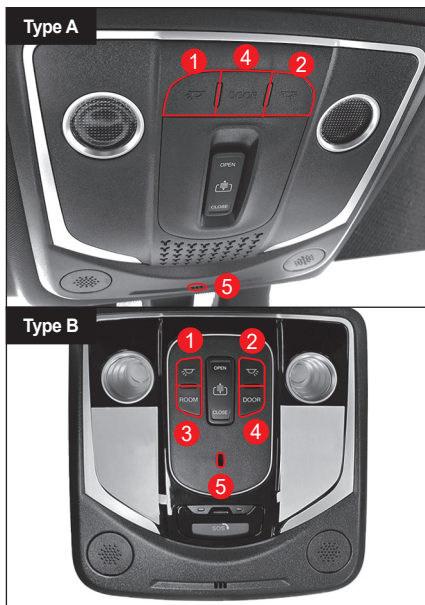

- 1 Driver seat spot switch
- 2 Front passenger seat spot switch
- 3 Driver/passenger/center room lamp/spot switch
- 4 Door-linked switch
- 5 Front spot lamp

### Warning

- Avoid using the interior room lamp when driving at night or in a dark place. The light of the interior room lamp may obstruct the front vision of a driver, causing an accident.

### Notice

- When the interior room lamp is turned on after the engine is turned off, the room lamp turns off automatically after approximately 10 minutes in order to prevent depletion of the battery.

### Driver seat spot switch

When you press the switch (1), the driver seat front room lamp turns on.

### Front passenger seat spot switch

When you press the switch (2), the front passenger seat front room lamp turns on.

### Driver / passenger / center room lamp spot switch

When you press the switch (3), the driver / passenger / center room lamp turns on.

### Door linkage switch

When you open the door with the switch (4) pressed, the front room lamp and the center room lamp turn on, and when you close the door, those lamps turn off.

### Front spot lamp (5)

It illuminates when the tail lamp is turned on. It illuminates the front center area dimly. (Comes on only when sunroof is selected)

### Linkage function between the smart/rekes key and the front room lamp

When you unlock the door using the smart/rekes key with the front room Lamp door linkage switch pressed, the driver seat and front passenger seat room lamps turn on for 30 seconds.

At this time, when you lock the door by pressing the Door lock button on the smart/rekes key, the driver seat and front passenger seat room lamps turn off immediately.

### Caution

- Do not leave the door open for a long time with the room lamp linked to the door or leave the vehicle when the room lamp is turned on. If the room lamp stays on for a long period of time, the battery may be depleted.

## Center room lamp



Pressing the center room lamp switch turns on the center room lamp. Pressing the switch again turns off the center room lamp. The center room lamp comes on when the door is opened regardless of the center room lamp switch operation if the door coupled switch is pressed in.

### Caution

- Do not open the door for a long period of time with the Door linkage switch pressed. If the center room/luggage room lamp stays on for a long period of time, the battery may be depleted.
- Do not leave the tailgate not closed completely for long period of time. If the center room/luggage room lamp stays on for a long period of time, the battery may be depleted.

## Luggage room lamp



- Pressing the switch (1) turns on the lamp and pressing it again turns it off with the tailgate open. (self-return type)
- When you close the tailgate with the luggage compartment lamp on, the luggage compartment lamp goes off.

## Sun visor/mirror lamp

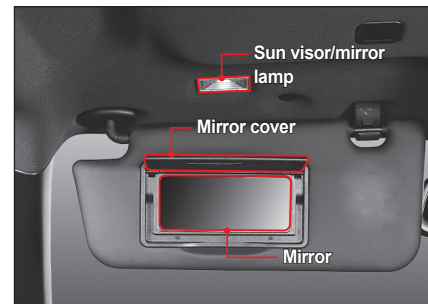

When you pull the sun visor down and open the mirror cover, the lamp turns on.

When you close the mirror cover, the lamp turns off.

### Caution

- Be sure to close the mirror cover after using the sun visor mirror. Failure to do so may cause the sun visor lamp to stay on and the battery may be depleted. Also, an open mirror cover may cause injury.

### Notice

- When you pull the sun visor down and use it as a sunshade, you can adjust the position of the sun visor.

## Glove box lamp



When you open the glove box, the lamp turns on, and when you close the glove box, the lamp turns off.



### Caution

- Leaving the glove box opened may cause injury to an occupant in the event of an accident or sudden braking. Be sure to drive the vehicle with the glove box closed.

## Mood lamp\*

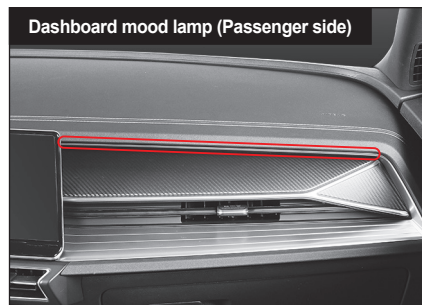

- When the mood lamp is set to enabled, the mood lamp is always lit if the engine is started or the ignition switch is turned on.
- When the tail lamp is turned on, the mood lamp gets dim and gives out a soft light.

## Mood lamp setting

- 1 Press the MODE button on the smart audio.
- 2 Press the setting icon on the MODE menu.
- 3 Press the Vehicle Interlock.
- 4 You may select one of six colors and choose auto change or manual color.
- 5 Scroll down to the bottom of the room lamp selection screen to see following additional settings menu:
  - ON/OFF  
Turn on and off the entire interior mood lamps.
  - Daytime OFF  
Disables in the daytime.

## e-call (Emergency call)\*

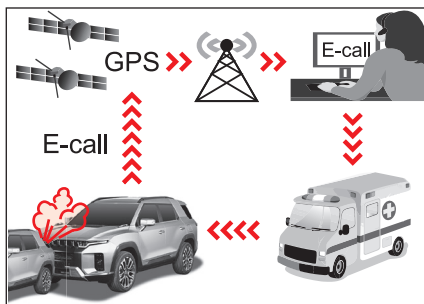

1. Accident occurs
2. Wireless network
3. Call center (PSAP)
4. Emergency center

The e-call is a system to minimize casualties by enabling the relevant information to be passed on to the nearest control center automatically or manually so that immediate action can be taken in case of traffic accidents and emergencies.

- SOS button: When the driver or passenger press this button, e-call is made to the service associate at the PSAP center.
- Test button (Russia only): This button is used to check the system performance. The driver should not press the Test button arbitrarily to activate the test mode.

### Notice

- **The Test button is the button to enable the test mode, which is used only by experts for the KG Mobility Authorized Service Center to check system performance.**

- LED indicator: When turning the ignition on, the red and green LEDs light up for 3 seconds. Then, this LED will go off during normal operation. In the event of an issue with the system, the red LED lights up or blinks.

### Caution

- **If the red LED is still lit under normal driving conditions, it may indicate a malfunction of the E-CALL system.**
- **Contact the nearest authorized KG Mobility Dealer immediately to determine whether the E-CALL system is faulty or not.**
- **Otherwise, normal operation of the E-CALL system is not guaranteed. The vehicle owner is responsible for the consequences of not observing the instruction above.**

## How to use E-CALL system

### AutoCall Mode



The ERA-GLONASS (eCall) device automatically makes an emergency call to a single duty dispatcher service for the timely implementation of rescue operations in the event of a car accident.

For the timely provision of assistance and support, the ERA-GLONASS (eCall) system automatically transmits data on a traffic accident to a single duty dispatcher service.

In this case, the emergency call cannot be terminated by pressing the SOS button, and the ERA-GLONASS (eCall) system remains in the connected state until the Unified Duty Control Service operator receiving the call disconnects the emergency call.

Notice
<ul style="list-style-type: none"> <li>• <b>In cases of insignificant cost of accidents, the ERA-GLONASS (eCall) system may not make an automatic emergency call. In this case, it is possible to make an emergency call in manual mode by pressing the SOS button.</b></li> </ul>

Notice
<ul style="list-style-type: none"> <li>• <b>The operation of the system will be impossible if there is no coverage of mobile communication networks and no GPS and GLONASS signal. (In Case of EU : Galileo Added)</b></li> </ul>

### Manual Mode



The driver / passenger can make an emergency call in single dispatch service manually by pressing the SOS button to call emergency services.

Call to the emergency service using the ERA-GLONASS system can be canceled by pressing the SOS button again only before establishing a connection with the operator of the single duty-dispatch service. (Russia)

Call to the emergency service using the eCall system can be canceled by re-pressing the SOS button within 3 second. (EU)

After activating an emergency call in manual mode for timely assistance and support system ERA-GLONASS (eCall) transmits data on a traffic accident / other incident to the operator of the single duty dispatcher service during a call for help by pressing the SOS button.

- Stop your vehicle at a safe place.
- Lower the e-call button cover.
- Press the SOS button. (Minimal data set for the vehicle and its location is registered to the mobile network)
- The call is connected to the operator at the e-call center.
- EU: MSD (Minimum Set of Data) sent before the emergency call is made, not after it does

- Russia: MSD (Minimum Set of Data) sent before the emergency call is made, not after it does
- EU: For the manual emergency call, you can cancel within 3 seconds after pressing the button.
- Russia: You can cancel before the call is connected.

### Test mode

- Russia: When you has replaced and checked the e-call system, you can use the Test button to activate the SOS test mode.

The driver should not press the Test button arbitrarily to activate the test mode.

There is a technical possibility device performance checks ERA-GLONASS installed on your car. In order to prevent erroneous signals anxiety and malfunctioning device, it is necessary to keep checking the device regularly ERA-GLONASS installed in the auto- mobile phone checks are allowed exclusively authorized to the staff in the service area in accordance with this manual (on enabling user testing interface). ERA-GLONASS device check mode is started by pressing a button. "Test Button". The test mode starts with voice guidance to verify performance device ERA-GLONASS. During the performance test of the ERA-GLONASS device, the red and green LEDs remain on. To deactivate the verification mode during the voice guidance output, it is not necessary to press the SOS test button again.



- EU: When you have replaced and checked the e-call system, you can use the scan tool to activate the SOS test mode.

#### **e-call can't be canceled when:**

- e-call is made automatically by crash signal from the air bag unit (terminated when an operator at e-call center ends the call)
- 3 seconds is elapsed since manual emergency call made by pressing the SOS button was connected (for EU)
- Operator at e-call center answers the call, for manual emergency call made by pressing the SOS button

#### **Notice**

- The battery of the ERA-GLONASS (eCall) system provides power for one hour in case the main power supply of the vehicle is turned off as a result of a collision in an emergency situation.

#### **Notice (Russia only)**

- During the operation of KG Mobility transported vehicles (commercial name Korando) in the territory of the Eurasian Economic Union (EAEU), incl. On the territory of the Russian Federation, with the installed UNIT ASSY-ECALL models, which include a multi-chip SIM / eUICC chip, the installation of additional profiles will be prohibited. And in this case, the packet transmission on these samples will be blocked.

#### **Warning**

It can be dangerous to remain in the vehicle, even if you have pressed the SOS button in an emergency if:

- you see smoke inside or outside of the vehicle, e.g. if there is a fire after an accident
- the vehicle is on a dangerous section of road
- the vehicle is not visible or cannot easily be seen by other road users, particularly when dark or in poor visibility conditions

There is a risk of an accident and injury. Leave the vehicle immediately in this or similar situations as soon as it is safe to do so. Move to a safe location along with other vehicle occupants. In such situations, secure the vehicle in accordance with national regulations, e.g. with a warning triangle.



### Notice

1. Our eCall system provides 112-based eCall service only and conforms to the General Data Protection Regulation specified in EU laws.
2. Processing of such data is strictly limited to the purpose of handling the emergency eCall to the single European emergency number 112
3. Type of data and its recipients
  - MSD Data Items
    - 1) Call Type : Auto Call / Manual Call
    - 2) Test Call : Test Call / Emergency Call
    - 3) Position Can Be Trusted : Yes/No
    - 4) Vehicle Type : M1/M2/M3/N1/N2/N3
    - 5) Vehicle identification number
    - 6) Propulsion Storage Type : Gasoline, Diesel
    - 7) RTA event timestamp : Road Traffic Accident event timestamp
    - 8) Vehicle Location : Latitude, Longitude
    - 9) Vehicle Direction : Vehicle orientation at the time of event
  - Call Log Data Items
    - 1) Trigger time : Time of call initiation event (crash detected or button press).
    - 2) DTC : Diagnostic Trouble Code
    - 3) Tigger type : Manual Call / Auto Call / Retry Call
    - 4) RSSI : GSM(2G) or UMTS(3G) signal strength
    - 5) Ec/No : Energy Carrier/ noise power density
    - 6) Call type : GSM(2G) / UMTS(3G) / Reserved
    - 7) Call end status : Reason for call end

4. The 112-based eCall in vehicle system is designed in such a was as to :
  - Ensure that the data contained in the system memory is not available outside the system before an eCall is triggered
  - Ensure that it is not traceable and not subject to any constant tracking in its normal operation status
  - Ensure that data in the system internal memory is automatically and continuously removed
5. The vehicle's owner has a right of access to data and as appropriate to request the rectification, erasure or blocking of data, concerning him or her, the processing of which does not comply with the provisions of Directive 95/46/EC.
6. The data subject has a right to complain to the competent data protection authority if he or she considers that his or her rights have been infringed as a result of the processing of his or her personal data.

# Wiper and washer fluid

## Windshield wiper

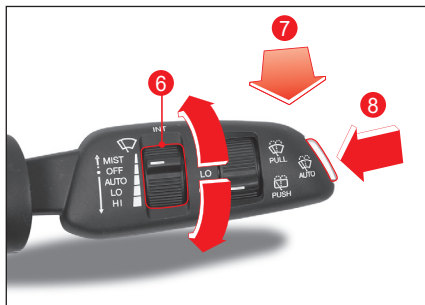
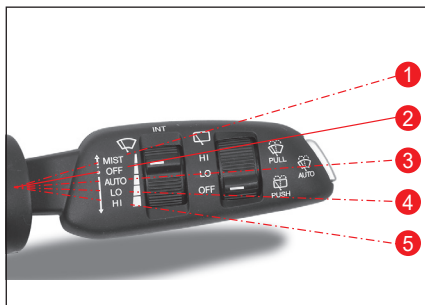

### 1 MIST

The wiper operates while lifting the wiper operation lever up.

When you release the lever, the level returns to the OFF position and stops.

### 2 OFF

The wiper stops operating.

### 3 AUTO

The wiper operation speed is adjusted automatically according to the vehicle speed or the amount of rain (rain sensing wiper).

### 4 LO

The wiper operates in low speed.

### 5 HI

The wiper operates in high speed.

## Adjusting the operation speed of the windshield wiper

When the wiper operation lever is placed in the AUTO position, the operation speed of the wiper is adjusted.

When you lift the wiper operation speed control lever (6) up, the operation speed of the wiper becomes faster and when you pull the lever down, the operation speed of the wiper becomes slower.

### Notice

- When you place the wiper operation lever in the AUTO position with the START/STOP switch in the ON status, the wiper operates once.
- When it becomes dark so that the auto light operates, the wiper speed becomes faster.

## Front windshield and washer fluid linkage



This function sprays washer fluid automatically when the windshield wiper is operated.

It operates as follows according to the time to pull the wiper operation lever (7).

- Pull the lever for less than 0.6 second  
The washer fluid is sprayed and the wiper operates once.
- Pull the lever for 0.6 second or more  
The washer fluid is sprayed and the wiper operates for three times.
- Pull the lever continuously  
The washer fluid is sprayed and the wiper operates continuously.

## Front auto washer

With the wiper lever placed in the OFF position, press the Front auto washer switch (8).

The washer fluid is sprayed and the wiper operates for four times, and the washer fluid is sprayed again and the wiper operates for three times.

## Rear window wiper

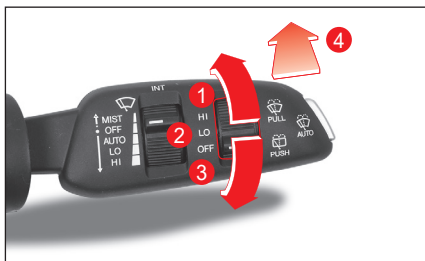

1 HI

The rear window wiper operates in high speed.

2 LO

The rear window wiper operates in low speed.

3 OFF

The rear window wiper stops operating.

## Rear window wiper washer fluid linkage function



This function sprays washer fluid automatically when the rear window wiper is operated.

The washer fluid is sprayed and the wiper operates while pushing the wiper operation lever (4).

When you release the lever, the level returns to the OFF position and stops.

## Rain sensing wiper\*

The rain sensing wiper detects the amount of rain and controls whether or not to operate the windshield wiper and its operation speed automatically.

The rain sensing wiper is activated when the wiper operation lever is placed in the AUTO position.

## Rain sensor



The rain sensor is integrated with the auto light sensor.

### Warning

- When you place the wiper operation lever in the AUTO position with the START/STOP switch in the ON status, do not touch the windshield where the rain sensor is located or wipe it with damp cloth. Doing so may activate the rain sensing wiper, causing injury to your hand or other body parts.



### Caution

- If the windshield is dry, do not only operate the wiper. Doing so may damage the windshield or the wiper blade. Be sure to activate the wiper after spraying the washer fluid.
- Before washing your vehicle, be sure to place the wiper operation lever in the OFF position. Failure to do so may activate the wiper by accident, causing body injury or damage to the vehicle.
- If it is not raining, place the wiper operation lever in the OFF position. It prevents the devices such as the rain sensor from operating unnecessarily.
- Activate the wiper in winter after verifying that the wiper blade is not frozen. Failure to do so may damage the windshield or the wiper blade.

## Outside rearview mirror

### Folding/unfolding the outside rearview mirror





- When you press the left side of the button (  ), the outside rearview mirror is unfolded.
- When you press the right side of the button (  ), the outside rearview mirror is folded.

### Auto folding/unfolding function

The following is the function to fold or unfold the outside rearview mirror automatically.

- When the door Lock/Unlock button on the smart key is pressed
- When the door handle Lock/Unlock button is pressed
- When the smart auto door lock function is activated
- When the auto approach function is activated

### Activating/deactivating auto folding/unfolding function





- Activating the function  
Place the Outside rearview mirror folding/unfolding button in the neutral (  ) position.
- Deactivating the function  
Press the left side (  ) or right side (  ) of the outside rearview mirror.

#### Caution

- **The outside rearview mirror auto folding/unfolding function is activated only when the vehicle has entered the theft monitoring mode.**

### Adjusting the outside rearview mirror



- 1 Outside rearview mirror selection dial (L  R  )
- 2 Outside rearview mirror control switch (   )

### Selecting the outside rearview mirror

Turn the selection dial (  ) to the left or the right and select a mirror you wish to adjust.

- Turning to the left: The outside rearview mirror on the driver seat side is selected.
- Turning to the right: The outside rearview mirror on the front passenger seat side is selected.

## Adjusting the angle of the outside rearview mirror

Adjust the angle of the mirror according to the driver's view by moving the Control button (2) up, down, left, or right.



### Warning

- Do not tint the driver seat and the front passenger seat windows. Doing so may make the outside rearview mirror less visible while driving at night, causing an accident.



### Caution

- The outside rearview mirror can be folded or unfolded for a certain period of time after the engine is turned off.
- Do not operate the mirror excessively after the engine is turned off. Doing so may cause depletion of the battery.
- Do not operate the mirror more than needed. When the mirror reaches its maximum adjustment angle, its movement stops, but the motor operates continuously while the switch is being pressed, causing the motor to malfunction.

- Do not operate the outside rearview mirror using hands instead of the motor switch. Doing so may cause the mirror and relevant devices to malfunction.
- Do not spray high pressure water directly onto the mirror while washing the vehicle. The outside rearview mirror operates electrically, so it may not operate normally due to an electrical device failure.
- If the mirror is frozen and does not move during winter, do not adjust it forcibly. Adjust the mirror carefully after removing ice by using deicing spray or soaking a soft cloth or sponge in warm water and wiping the frozen part with it.
- Do not scrape ice off even if the surface of the mirror is frozen during winter. Doing so may damage the surface of the mirror.

## Interior mirror

The inside rearview mirror can be adjusted up, down or side ways to obtain the best rear view.

### ECM room mirror\*

The ECM (Electronic Chromic Mirror) room mirror detects a light from a following vehicle automatically through the light sensor and lowers the reflection rate of the mirror to prevent glare for the driver.

- To adjust the angle of the interior mirror, hold and move the body of the mirror with your hand up, down, left and right to obtain the best rear view.



**Warning**

- Be sure to finish adjusting the mirror before driving.
- Never adjust the mirror while driving. Doing so may distract the driver, causing an accident.
- If the interior mirror is broken, the electrolyte inside the mirror may flow out. Be careful not to allow this electrolyte come into contact with your skin or eyes. If the electrolyte comes into contact with your eyes, wash it with water immediately and consult a doctor.

**Caution**

In any of the following cases, the automatic anti-glare function of the ECM room mirror may not operate.

- If the head light of a following vehicle is not beamed directly to the light detection sensor
  - When the rear window is tinted darker
  - If the gear shift lever is in the R(Reverse) position
- At this time, the automatic anti-glare function is suspended to enable easy identification of an object.

## Manual type inside rearview mirror



The inside rearview mirror can be adjusted up, down or side ways to obtain the best view by holding the body of the mirror with your hand.

## Manual Day/Night Adjustment (A)

You can manually adjust the rearview mirror by pushing or pulling its adjusting lever to avoid blindness at night due to other vehicles behind you.

**Warning**

- For your safety, adjust the mirror before driving off the vehicle.

**Caution**

- When you are not able to see the back of your vehicle at night, adjust the rearview mirror by holding the mirror body and pushing or pulling it to a desired angle so that you can secure a clear rear view.

# Heater and air conditioner

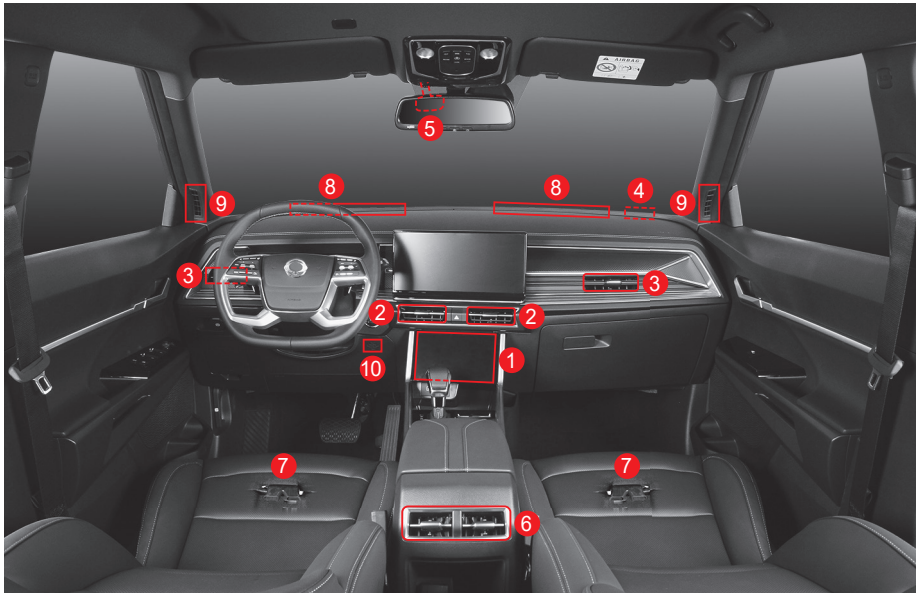

- ① Heater and A/C controls(Buttonless integrated control panel)
- ② Vents (front seat center)
- ③ Vents (both front seat sides)
- ④ Solar radiation sensor
- ⑤ Windshield fog detection sensor
- ⑥ Vent (rear seat center)
- ⑦ Rear foot duct (Bottom of front seat)
- ⑧ Center defroster vents
- ⑨ Side defroster vents
- ⑩ Interior temperature sensor

## Adjusting the direction of air distribution and blocking the air distribution

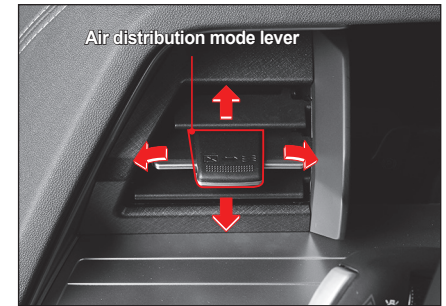

- Adjust air distribution  
You can adjust the direction of air distribution by moving the air distribution mode lever up, down, left and right.
- Open and close air vents  
If you push the air distribution mode lever all the way to the closing (☒) direction, the air vent closes and the air does not come out. If you put it in the opening (≡) direction, air comes out.

### Caution

- Do not attach a cup holder or other devices to the air guide pin of the air outlet. Doing so may damage the air guide pin or other relevant devices.

## Rear air distribution and fan speed control

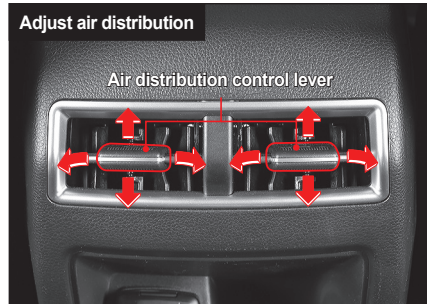

- You can adjust air distribution by moving the air distribution control lever at the vent up and down and left and right.

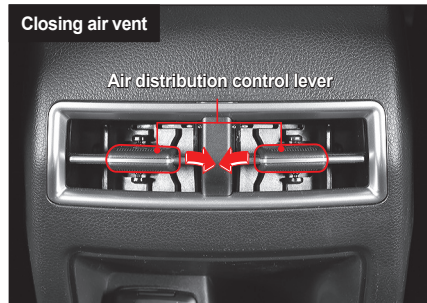

- You can close the air vent by pushing the air distribution control lever all the way in the direction of the arrow.

## Cautions for using the heater and air conditioner

### Replacing A/C refrigerant/oil

Be sure to replace the A/C refrigerant and oil with the products that meets the specified standard and capacity. Failure to do so may damage the air conditioner system.

Classification	Specifications	
	Type A	Type B
Standard	R-1234yf	R-134a
Refrigerant capacity	530 ± 30g	570 ± 30g
Oil capacity	120cc	120cc

#### Type A



#### Type B

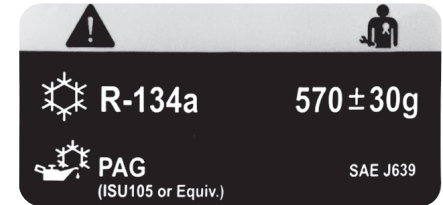





### Warning

- While driving, select the fresh air mode if possible or open the window and ventilate frequently to allow fresh air to flow in. Failure to do so may make the air inside the vehicle to be stuffy, causing headache or dizziness.
- Caution should be taken that if exhaust gas flows in, it may cause carbon monoxide poisoning.
- When you drive in an area where dust and smoke may flow in, pass the area using the recirculation mode and switch it to fresh air mode for ventilation.
- Do not sleep or stay inside the vehicle for a long period of time while operating the air conditioner or the heater with the doors and the windows closed during midsummer or midwinter. Doing so may cause suffocation due to lack of oxygen inside the vehicle.
- Never leave an infant, a small child or an elderly alone in the vehicle even for a short period of time during midsummer. The temperature inside the vehicle may increase, causing risks such as suffocation.
- Refrigerant is flammable which can cause the fire by the gas leakage or static, so be very careful when handling Refrigerant (R-1234yf).



### Caution

- Before driving the vehicle, open all windows to ventilate the air inside the vehicle properly for the health of occupants and a pleasant indoor environment. Especially, if the vehicle has been parked on a place exposed to direct sunlight for a long period of time, the temperature inside the vehicle may have increased, causing volatile organic compounds that are harmful to human body to be emitted.
- Do not start the engine while electrical devices with high electrical load such as the air conditioner and fan are running. In such case, it may be difficult to start the engine and the engine idle speed becomes unstable after the engine is started so that you may feel vibration greater than usual.
- When you drive up on a long sloping road continuously, turn on and off the air conditioner every 3 to 5 minutes. Failure to do so may overheat the engine, causing a failure.
- When you apply a sudden acceleration while the air conditioner is operating, the magnetic clutch in the compressor is detached and may create a clicking sound. This is a normal operation that lowers excessive pressure of the refrigerant to protect the air conditioner system.

- Be sure to operate the air conditioner at a low speed if you use the air conditioner again after it is not used for a while. If the air conditioner is not used for a long period of time, the oil in the compressor is not circulated, causing a failure.
- When you use the air conditioner after it is not used for a long period of time, there may be a smell from the air outlet. In such case, open the window and operate the air conditioner for 20 to 30 minutes to eliminate the smell.
- Do not turn off the engine suddenly while operating the air conditioner. The fan motor stops suddenly and cold or warm air in the duct is condensed in the pipe without being emitted to the outside, creating a bad smell. Before turning off the engine, turn off the air conditioner and emit air in the duct for 2 to 3 minutes in the fresh air mode.
- Do not operate the air conditioner for a long period of time while stopping the vehicle. Doing so may overheat the engine, causing a failure.
- If the engine is not running, do not operate the fan for a long period of time. Doing so may cause depletion of the battery.
- Operate the air conditioner once a week in seasons other than winter to circulate the oil in the air conditioner compressor and relevant parts smoothly. This helps you to maintain the air conditioner in its best condition.

## Heater & A/C Controls

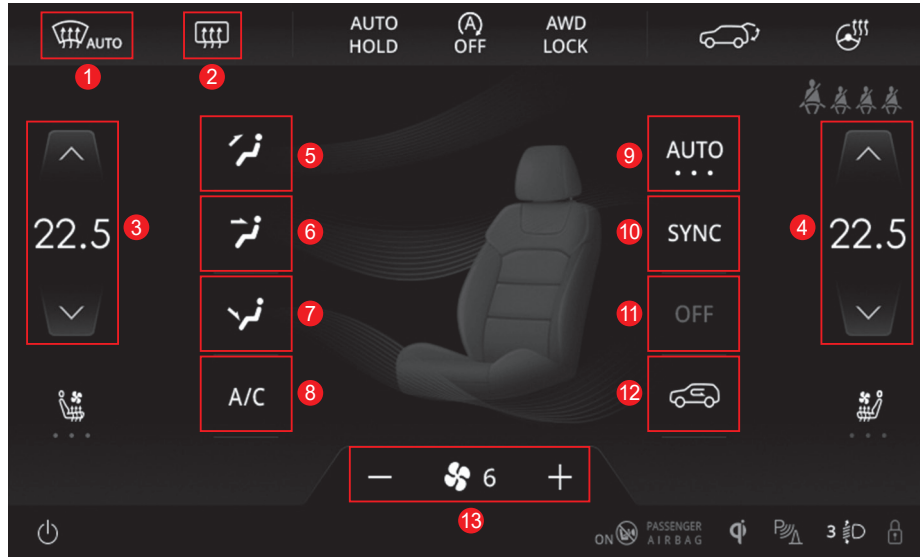

- 1 Defroster indicator (ADS)
- 2 Glass heater switch
- 3 Driver side temperature control switch
- 4 Passenger side temperature control switch
- 5 DEF mode air distribution switch
- 6 VENT mode air distribution switch
- 7 FOOT mode air distribution switch
- 8 A/C switch
- 9 AUTO switch
- 10 SYNC switch (to sync with driver side set temperature)
- 11 Heater and A/C ON/OFF switch
- 12 Air source selection switch
- 13 Fan Speed Control Switch

## Turning Heater and A/C On/Off

To turn the heater and air conditioner on or off, lightly touch the OFF switch (1).

- Heater & A/C OFF: White symbol shown
- Heater & A/C ON: Gray symbol shown

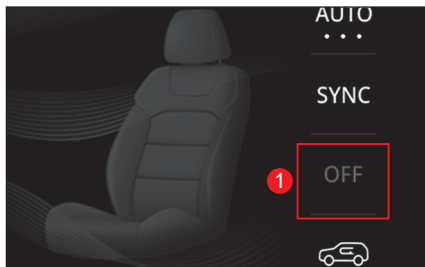

### Notice

- The heater and air conditioner will operate as previous operation condition when they are turned on.
- When the heater and air conditioner are off, touch the relevant operation switch to turn them on.

## Driver/Passenger Side Temperature Control

To adjust the temperature, lightly touch the driver/passenger side temperature control switch (1).

- The set temperature is indicated in the center of the temperature control switch (2).
- When the driver's seat set temperature synchronization (SYNC) indicator (3) is lit (white symbol shown), the driver's seat and the passenger seat's set temperature are changed equally.
- When the temperature control switch is operated, the increment values are:
  - 0.5°C on long touch.
  - 0.5°C on short touch.

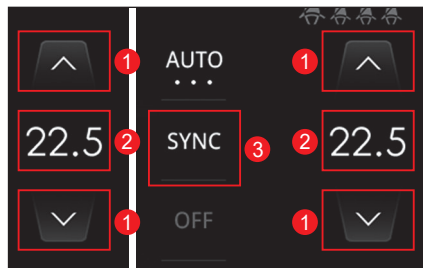

### Notice

- Touching the AUTO switch in manual mode changes the climate control system to AUTO mode and the climate functions are controlled automatically based on the set temperature.

## Independent Temperature Control (SYNC Off)

To independently adjust the set temperature for the driver's seat and front passenger's seat, operate as follows.

- Turn off the synchronization indicator (3) (gray symbol shown) by lightly touching the driver's seat temperature synchronization (SYNC) switch and the front passenger temperature control switch.
  - Synchronization indicator (SYNC) on: White symbol shown
  - Synchronization indicator (SYNC) off: Gray symbol shown

## Temperature Synchronization Control (SYNC On)

Lightly touch the driver's seat set temperature synchronization (SYNC) switch to turn on the synchronization light (white symbol shown) (3). Then the set temperature of the passenger seat will follow the one of the driver's seat.

### Notice

- Depending on the driver's seat set temperature, the air conditioner ON/OFF, air distribution, and air source mode are automatically set to:
  - Low temperature setting (LO): A/C ON, FACE mode, recirculation mode
  - High temperature setting (HI): A/C OFF, FOOT mode, fresh air mode

## AUTO Mode

To enter AUTO mode, operate as follows with the engine started.

- Briefly touch the AUTO switch (1).
  - AUTO mode on: White symbol shown
  - AUTO mode off: Gray symbol shown
- Set the desired temperature by lightly touching the temperature control switch.

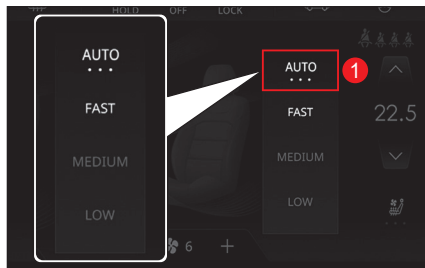

### Notice

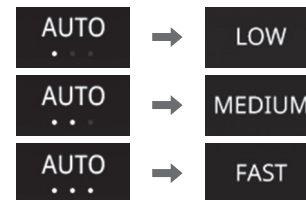

- In AUTO mode, the fan speed, air distribution and etc. are automatically adjusted according to the set temperature, room temperature, and outside temperature.
- Pressing the air source selection switch, fan speed switch, air distribution mode switch, A/C switch, or defroster switch in auto mode deactivates the auto mode and the system enters the manual mode.
- AUTO mode can be set in 3 steps.
- How to set AUTO mode
  - When you touch the switch briefly:  
The setting is changed in order of FAST → MEDIUM → LOW → FAST.
  - When you touch and hold the switch:  
A settings screen is displayed where you can select one of 3 levels (FAST / MEDIUM / LOW).
- The setting status is indicated by the dot(s) on the lower display bar.



## Manual Mode

Operate as follows with the engine started.

- Touch the ON/OFF switch (1).
- Set the room temperature by lightly touching the temperature control switch (2).
  - The currently set temperature is displayed (3).
- Lightly touch the fan speed switch - (decrease fan speed) / + (increase fan speed) (4) to set the fan speed one step at a time.
  - The current fan speed is displayed (5).
  - The fan speed can be changed quickly from 0 to 8 by touching the fan speed indicator (5).
- Lightly touch the air distribution mode switch to select the desired air distribution mode. (You can select more than one air distribution mode.)
  - DEF mode (6) switch
  - VENT mode (7) switch
  - FOOT mode (8) switch

- Press the air source selection switch (9) to switch between the fresh air and recirculation modes.
  - Air recirculation mode: 
  - Fresh air mode: 
- To use the air conditioner, lightly touch the air conditioner switch (10).

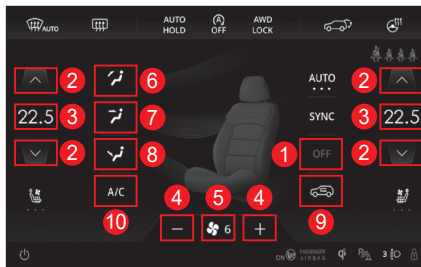

### Warning

- Do not use the recirculation mode longer than is needed. Doing so may cause headache or drowsiness due to lack of oxygen inside the vehicle. Also, moisture may occur on the window, impairing safe visibility and may result in an accident.
- Be careful not to allow exhaust gas to flow into the inside of the vehicle. Doing so may cause carbon monoxide poisoning.
- Pass an area where dust and smoke may flow in using the recirculation mode. After that, switch the mode to the fresh air mode for ventilation.

### Notice

- When you press the AUTO switch in the manual mode, the mode changes to the AUTO mode, and each mode is controlled automatically according to the set temperature.

## Air Distribution

Lightly touch the air distribution mode switch to select the desired air distribution mode. (You can select more than one air distribution mode and selected mode is indicated by a white symbol.)



DEF mode (1) switch

Blowing air in the direction of the windshield and door glasses (typical settings for defrosting and defogging)



VENT mode (2) switch

Blowing air in the direction of driver's and/or passenger's face (typical settings for cooling)



FOOT mode (3) switch

Blowing air in the direction of driver's and/or passenger's feet (typical settings for heating)

### Notice

- When the air distribution is set to FOOT mode, some air is blown in the direction of the windshield and door glasses to prevent moisture buildup on the windshield.



## Activating glass heater

When frost or fogging occurs in the window, the glass heater can be activated to remove it.

- To activate the glass heater, lightly touch the glass heater switch (1). (The glass heater operates for about 12 minutes and the symbol changes to orange.)
- To deactivate the glass heater, lightly touch the glass heater switch (1) again. (The glass heater stops working and the symbol changes to white.)



### Rear window heater

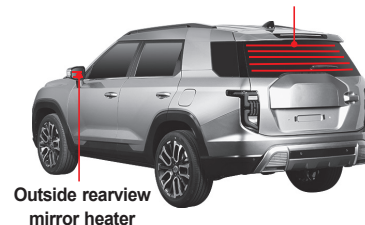

Outside rearview mirror heater

### Notice

- The glass heater only works when the engine is on.
- When the glass heater is activated, the rear window heater and the outside rearview mirror heater are operated simultaneously.
- If the glass heater is operated again within 10 minutes after completing operation for 12 minutes, it will only operate for approximately 6 minutes.

## How to Dehumidify Window Glass

- 1 Lightly touch the defroster and defogger switch (1).  
(The symbol changes to orange.)
- 2 Lightly touch the fan speed switch - (decrease fan speed) / + (increase fan speed) (2) to set the fan speed.  
(The current fan speed is displayed (3).)
  - To quickly remove moisture from the windows, set the fan to high speed.
  - To defrost the outdoor side window, set the temperature to high.



### Warning

- If it is raining or humid, switch the air source selection switch to the fresh air mode and set the air distribution to the windshield. With rainy or highly humid condition, fog may appear on the windows as well as the windshield even the A/C is ON. If this happens, it is dangerous to drive because of poor frontal and side visibilities.

### Caution

- Avoid excessive use of A/C with the defroster and defogger turned on and the air distribution set to footwell or to footwell and the windshield. Otherwise, a temperature difference between indoor and outdoor may cause the fogging on the outside of the windshield. If this is the case, use the wiper blades to immediately clear fog on the windshield and change the air distribution mode to vent mode (toward face) to minimize the temperature difference.
- Make sure to remove any foreign materials such as snow and leaves on the air inlets to avoid window fogging, especially in winter and summer.

### Notice

- Touching the defroster and defogger switch (1) activates the air conditioner automatically and sets it to fresh air mode and fan speed of 1st level or higher. Touching the switch again returns the system to previous condition.
- To prevent the windshield from fogging up normally, it is recommended to set the air source selection switch (4) to the fresh air mode.

## Auto Defogger System (ADS)

In the InfoCon navigation system, ADS (Auto Defogger System) is an auxiliary device that enables safe driving by automatically removing fog when fog is detected on the indoor windshield while the heater and A/C are in operation. To use this function, you must enable the automatic defogger ("Check" under Vehicle Settings → Defogging → Auto Defogger).



## Operation levels of auto defogger system

As the humidity on the inside surface of windshield becomes higher, the auto defogger system operates at a high level. For example, if the humidity cannot be controlled by switching to the fresh air mode that is level 1, the operation is carried out from level 2 to level 4 in consecutive order to control the humidity.

- Level 1 - Switch to the fresh air mode
- Level 2 - Air conditioner ON
- Level 3 - Air distribution towards the windshield
- Level 4 - Increase the fan speed towards the windshield

### Warning

- Do not switch the mode to the recirculation mode while the auto defogger system is operating. Doing so may decrease the moisture removal effect, impairing safe visibility and may result in an accident.
- Do not remove the sensor cover on top of the windshield forcibly. Doing so may damage the auto fog detection sensor.

## Eco Mode

This is a function that maintains the air source selection mode to recirculation mode for 20 minutes when the vehicle is started, in order to quickly lower the vehicle's cabin temperature during hot weather.

### Conditions for activation

- Air source selection: fresh air mode
- Ambient temperature: 24°C or higher
- A/C status: ON

### Caution

- The vehicle enters eco mode only once upon starting, with the above operating conditions met.
- When the A/C is changed to the fresh air mode with the eco mode activated, the eco mode is deactivated.
- After 20 minutes of eco mode (recirculation mode) operation, the air source selection changes to the state before eco mode is activated.





## Buttonless Integrated Control Panel Screen Composition

### Items to be displayed at all times



- 1 Defroster indicator (ADS)
- 2 Glass heater switch
- 3 Favorite menu switch
- 4 Tailgate switch
- 5 Steering wheel heating switch
- 6 Passenger and rear seat belt reminder indicator
- 7 Buttonless Integrated Control Panel Screen Off switch
- 8 Wireless charging indicator
- 9 Front PAS status indicator
- 10 Headlamp leveling status indicator
- 11 Door lock/unlock indicator

## Heater and A/C control (FATC) screen

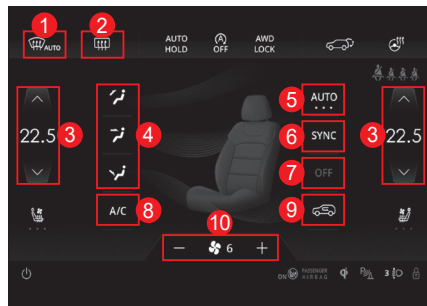

- 1 Defroster indicator (ADS)
- 2 Glass heater switch
- 3 Driver/Passenger Side Temperature Control Switch
- 4 Air distribution DEF / VENT / FOOT mode switch
- 5 AUTO switch
- 6 SYNC switch (to sync with driver side set temperature)
- 7 Heater and A/C ON/OFF switch
- 8 A/C ON/OFF switch
- 9 Air source selection switch
- 10 Fan Speed Control Switch

## Front seat heating / ventilation control screen



- 1 Driver/passenger seat heating switch
- 2 Driver/passenger ventilation switch

### Notice

- If there is no operation for about 5 seconds, it moves to the heater and A/C control (FATC) screen.

## Buttonless Integrated Control Panel Screen Off

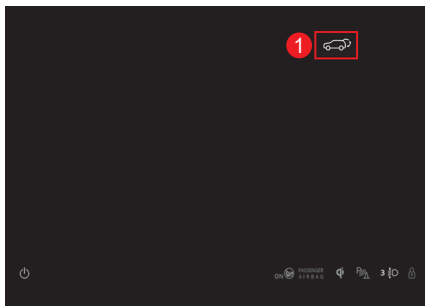

- 1 Tailgate switch

## Vehicle settings switch

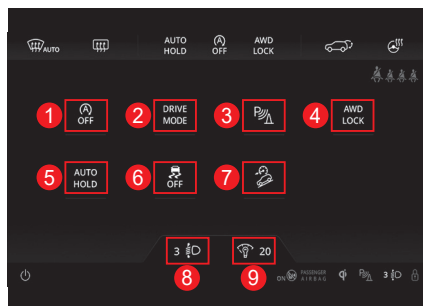

- 1 ISG OFF switch
- 2 Drive mode switch
- 3 Front obstacle detection ON/OFF switch
- 4 AWD LOCK switch
- 5 AUTO HOLD switch
- 6 ESC OFF switch
- 7 HDC switch
- 8 Headlamp leveling switch
- 9 Room lamp switch

### Notice

- If there is no operation for about 5 seconds, it moves to the heater and A/C control (FATC) screen.

## Buttonless Integrated Control Panel Favorites

### How to set Favorites menu

For your convenience, you can register 3 favorite menus.

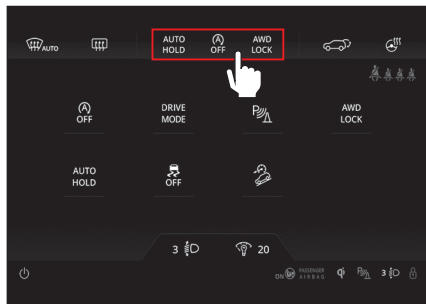

- 1 Touch and hold the Favorites menu to enter the setting screen.



- 2 Press and hold the switch you want to add to the Favorites menu, then drag and drop it to the Favorites list.
- 3 The menu is now visible in the Favorites list.

## Buttonless Integrated Control Panel Reset

If the following occurs while using the buttonless integrated control panel, please initialize and reboot the system:

- Screen won't touch or switch
- Pop-up screen displayed and system not working

### How To Reset

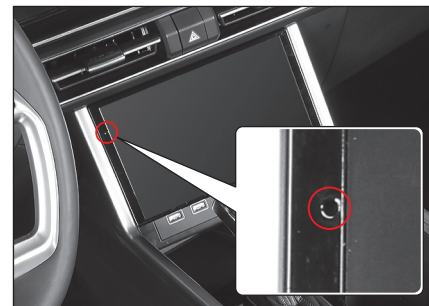

Turn the ignition switch to "IGN ON" position and press the RESET button on the upper right corner of the buttonless integrated control panel for about 1 second.

#### Notice

- The system reboot takes about 10 seconds or less.

# Steering wheel

## Adjusting the height/length of the steering wheel

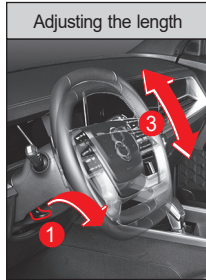
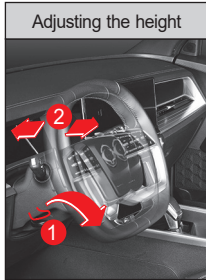

- 1 Push down the steering wheel telescoping/tilt control lever (1).
- 2 Adjust the position of the steering wheel upwards and downwards (2) and forwards and backwards (3) properly.
- 3 Lift the steering wheel telescoping/tilt control lever (1) up.

After adjusting the steering wheel, check that the steering wheel is secured firmly.

### Warning

- Check that the steering wheel is secured firmly before driving.
- Do not adjust the steering wheel while driving. Doing so may cause a serious accident.

### Caution

- Do not turn the steering wheel left or right to the end and maintain such position for 10 seconds or more with the engine started. Doing so may damage the power steering system due to overload.
- In winter (-10°C or below), starting off the vehicle immediately after starting the engine while the power steering fluid is cold can sometimes cause a momentary delay in the power steering, so be sure to let the engine idle properly before starting.

## Steering wheel heater\*

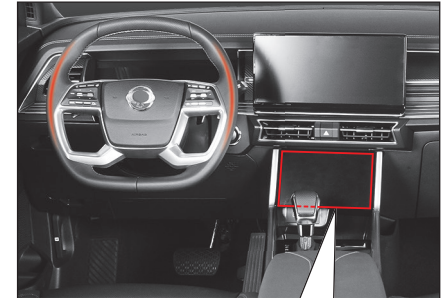

- To activate the steering wheel heater, touch the steering wheel heater switch while the engine is running. The operation indicator on the instrument cluster turns on.
- To deactivate the Steering wheel heater, touch the Steering wheel heater switch again. The operation indicator on the instrument cluster turns off.



#### Caution

- Do not attach an assist knob to the steering wheel. Doing so may damage the heater in the steering wheel and impede safe steering.

#### Notice

- The status of the Steering wheel heater switch is maintained even if the engine is turned off and on again.

## Horn

Warning horn is sounded while the horn is being pressed.



#### Caution

- Using the horn may startle pedestrians. Use it carefully only when it is necessary.

## Smart audio\*

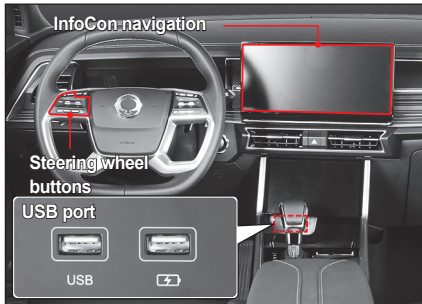

### ⚠ Caution

- The Android auto and Car Play in the vehicle may not be supported or some functions may not be compatible according to the specification or characteristics of the relevant device.
- The connection of the relevant devices to the vehicle may not be supported or some functions may not be compatible according to the specification or characteristics of the relevant video player, MP3 player.
- The method of use may be different or the connection to the vehicle may not be supported according to the specification or characteristics of the relevant Bluetooth device.

- Some USB storage devices and SD cards may not be compatible with the relevant device in the vehicle. Using a non-compatible memory card may damage the relevant device in the vehicle, memory card or data saved in the memory card.

### Notice

- For detailed explanation regarding the infotainment system in the vehicle including smart audio and slots for multimedia, refer to the owner's manual provided separately.
- If you wish to connect an external device to the infotainment system in the vehicle including smart audio and slots for multimedia, refer to the owner's manual of the relevant device for how to connect and use such device.

### ⚠ Warning

- The rear camera screen does not work during software update. Always stop the vehicle to update the software and do not drive the vehicle until the update is completed.
- Be careful when reversing since the rear obstacle may be hidden by the warning messages and parking guide lines if the rear camera system is activated.

- The smart audio has an 9-inch touchscreen and four buttons, and can be operated with the buttons on the steering wheel.
- The USB port allows you to connect external devices to the multimedia socket.
- Including Bluetooth and rear view camera, the following apps are supported: Android Auto (for Android device) and CarPlay (for iOS device). (iOS devices can be charged through the USB port.)
- The operation information of the smart audio is displayed on the instrument cluster.

### ⚠ Caution

- During driving, video is not supported and only audio is supported for safety. When the vehicle stops, video is supported again.
- Do not use the audio system for a long period of time with the engine not started. Doing so may cause depletion of the battery in the vehicle.

## AV/Navigation\*

- You can operate the AV/Navigation on the 9-inch touch screen and the steering wheel buttons (voice recognition function is supported).
- An external device can be connected to the slots for multimedia using the USB port (iPod, iPhone and iPad are supported).
- Android auto (Android devices are supported) and Car Play (iPhone is supported) as well as Bluetooth, SD card (for navigation), rear camera and around view camera are supported.

The operation information of the AV/Navigation is displayed on the instrument cluster.

### Warning

- **Be sure to use the navigation and video-related functions after stopping or parking the vehicle at a safe place for safe driving.**

### Caution

- **Do not use the AV/navigation system for a long period of time with the engine not started. Doing so may cause depletion of the battery in the vehicle.**

### Warning

- **The rear camera screen does not work during software update. Always stop the vehicle to update the software and do not drive the vehicle until the update is completed.**
- **Be careful when reversing since the rear obstacle may be hidden by the warning messages and parking guide lines if the rear camera system is activated.**

## Slots for multimedia



With the USB port, you can connect the external music / video playback devices such as USB storage and iPod to the vehicle.

### Caution

- **Some USB storage and external music / video playback devices may not be played through the USB port.**



## Operating from the steering wheel



- 1 Bluetooth hands-free button
- 2 Mute button / Volume control lever
- 3 Media search (SEEK) lever
- 4 Mode selection button
- 5 Voice recognition button
- 6 LDWLKA SET button

## Bluetooth hands-free

You can connect and use your mobile phone in the vehicle through Bluetooth.

### Notice

- For detailed explanation regarding the Bluetooth hands-free, refer to the owner's manual provided separately.

## MUTE Mute

- Tapping the Mute button with the audio system turned on turns off the voice output. Tapping it again turns on the voice output.
- Pressing and holding down the Mute button with the audio system turned on turns off the audio system.

## Controlling the volume

Raises or lowers the volume.

## Searching for media (SEEK)

Classification	Tap up/down the SEEK lever	Push up/down and hold the SEEK lever
When playing on the media screen	Plays the previous/next track	Moves to the previous/next list of tracks (The current playback is maintained)
When playing on a screen other than the media screen	Plays the next/previous track	Moves to the next/previous list of tracks (The current playback is maintained)
When listening in the radio screen	Moves to the previous/next saved channel	Moves to the next/previous available radio frequency
When listening in screens other than the radio screen	Moves to the next/previous saved channel	

## MODE Selecting the mode

- The AV mode changes each time you press the Mode button.
- Tapping the Mode button with the AV system turned off, turns on the AV system.

## Voice recognition function

This convenient function allows you to use various functions of the infotainment system through voice recognition.

## Antenna



When the audio system is turned on, the antenna receives the following radio waves.

- Smart audio: GPS, radio, DAB (EU, GCC), GSM (e-call)
- AV/Navigation: GPS, radio, DAB, GSM

# USB charging port

USB charging port (front side of front seat cup holder)

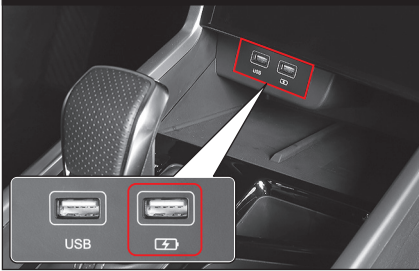

USB charging port (rear side of center console)



You can charge devices such as a smartphone or tablet PC using the USB charging port.

- In order to charge, connect the charging cable of the device to charge to the USB charging port (5V / 2.1A, 10.5W) in front side of the front seat cup holder with the engine started.
- With the engine turned on, connect the charging cable of a device you wish to charge to the USB charging port (5 V-2.1 A) at the rear side of the central console.
- For charging complete and charging progress, refer to the display screen of the device being charged.

## Caution

- **Connect a device you wish to charge to the USB charging port after starting the engine and separate the device before turning off the engine. Failure to do so may damage the device being charged by sudden voltage variation when starting or turning off the engine.**
- **Caution should be taken that using the USB charging port with the engine turned off may cause depletion of the battery.**
- **Do not charge a device whose current consumption exceeds 2.1 A with the USB charging port. Doing so may disable charging, making the charging time longer or damage the USB charging port and the connected device.**
- **Caution should be taken that connecting the USB charging cable incorrectly may damage the fuses in the vehicle or the connected device due to a short circuit.**
- **Caution should be taken that if a foreign material or liquid such as water enters into the USB charging port, the charging port and the device may get damaged.**

## Notice

- **The charging speed of the USB charging port may vary depending on the type of and compatibility with the connected device, charging cable and other vehicle conditions.**

## Power socket

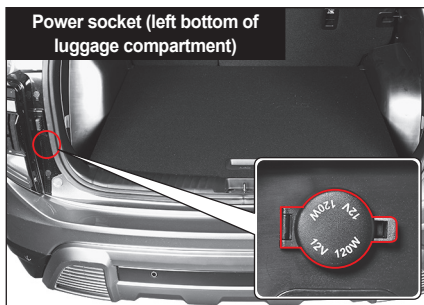
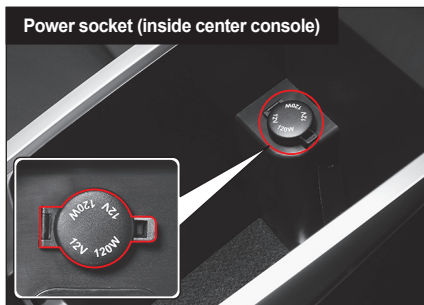

The power socket (12 V, 120 W) is provided in the vehicle to enable the use of a separate electrical device.

### Warning

- Caution should be taken that inserting a finger into the power socket may cause injury such as an electric shock.
- Be sure to use a separate electrical device after connecting it to the power socket. Modifying the wires in the vehicle arbitrarily and using an electrical device may cause an accident such as a fire.
- Observe the rated capacity of the power socket (12 V, 120 W). Failure to do so may cause the power socket and the connected device to malfunction or fail.
- Caution should be taken that using the power socket with the engine turned off may cause depletion of the battery.
- If the power socket is not used, be sure to close the power socket cover. Failure to do so may let foreign material or liquid such as water enter into the power socket, causing damage to the device as well as an electric shock.

## Sun visor and card holder (driver seat)

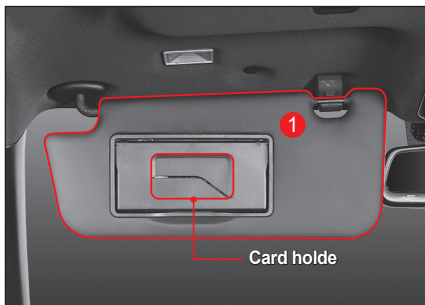

### Sun visor

You can block out the sun from the front or the sides by lowering the sun visor (1).

- You can adjust the position of the sun visor (2) for blocking out the sun from the sides.

### Card holder

The card holder is provided in the inside cover of the sun visor. It is convenient to store a motorway toll ticket or a card.

#### Caution

- **Adjusting the sun visor or using the card holder or mirror while driving may lead to careless driving or block the driver's vision, resulting in an accident.**
- **Adjust or use the sun visor and card holder after stopping or parking the vehicle.**

## Mirror and lamp

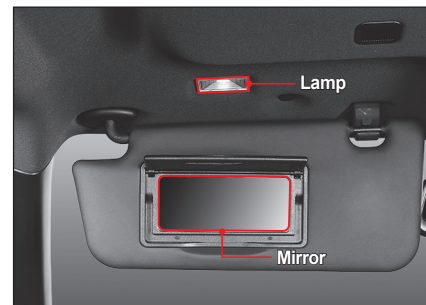

- You can use the mirror by lowering the sun visor and lifting up the cover.
- When you lift up the mirror cover, the lighting lamp turns on.

#### Caution

- **Be sure to close the mirror cover after using the sun visor mirror. Failure to do so may cause the sun visor lamp to stay on and the battery may be depleted. Also, an open mirror cover may cause injury.**

## Grip handle/coat hanger



- The grip handle is installed on the side ceiling of the front passenger seat and rear seats (head lining).
- The coat hanger is included in the grip handle on the ceiling of the rear seats.

### Warning

- **Do not hang articles other than cloth on the coat hanger. Doing so may cause the side air bag to operate at the time of an impact of an accident, resulting in damage to the vehicle as well as the injury or death of an indoor occupant.**

### Caution

- **Do not hang a heavy cloth on the coat hanger. Doing so may damage the coat hanger and the ceiling (head lining).**

## Rear seat door roller blind\*

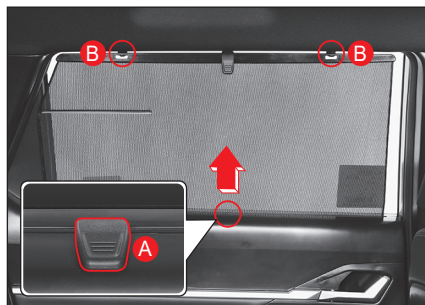

To block external light coming through the rear seat glass, operate the roller blind as follows:

- 1 Hold the roller blind ring (A) and lift it in the direction of the arrow.
- 2 Hang the roller blind on the hooks (B) mounted on both sides.

### Caution

- Hanging the roller blind on only one hook may cause the roller blind to get deformed. Therefore, make sure to hang the roller blind on the both hooks.
- If any foreign material, such as coin, get inside the roller blind, it may cause a jam during its operation. Be careful not to do so.
- When lowering the roller blind, always grasp the handle in that status and slowly move it downward to rest it in place and then release the handle.
- Do not hang the objects other than the roller blind on the hooks.
- Pulling the roller blind forcibly or applying an excessive force to it may cause it to get crushed or deformed.
- Be careful when using the roller blind with the rear glass lowered as it may come off the hook.

## Storage unit

### Front seat/rear seat cup holder\*

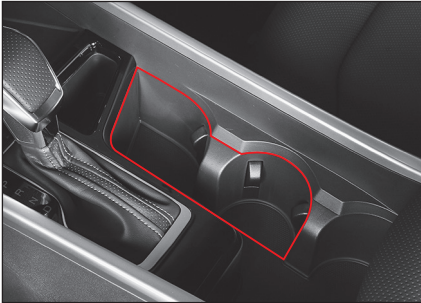

The cup holder is provided in front of the central console section.

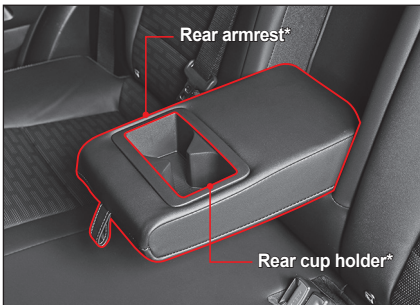

There is a cup holder when you lower the rear seat armrest.

#### Caution

- Caution should be taken that hot liquid in the cup may overflow or spill, causing a burn.
- Pay particular attention while driving since the cup may fall down or the liquid in the cup may spill over.
- Caution should be taken that if liquid in the cup spills over into the switches or operation buttons, it may cause trouble to the system functions.

### Front storage (W/O WPC)

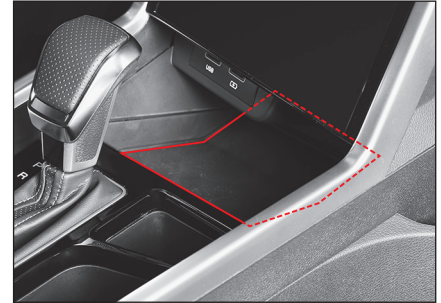

The front storage is provided near the gear shift lever. Use it for storing a small article.

#### Caution

- Caution should be taken that an article in the front storage may fall down or interrupt the operation of the gear shift lever.

#### Notice

- The front storage only applies to the vehicles without wireless charging system (WPC).

## Front side storage box

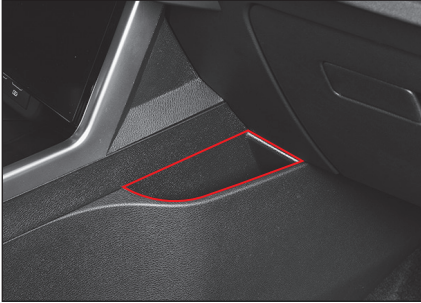

There is a storage box on the side of the center console (passenger side).

## Rear storage box



There is a pocket type storage box at the back side of the center console. This is suitable for storing small items.

## Glove box

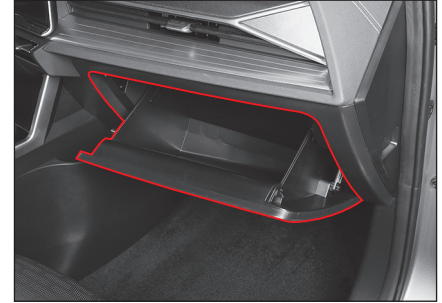

The glove box can be used for storing documents related to the vehicle registration or articles used in the vehicle conveniently.

- Pull on the glove box lever to open the glove box.





### Caution

- Leaving the glove box opened may cause injury to an occupant in the event of an accident or sudden braking. Close the glove box while driving.
- Do not store any flammable materials or a cigarette lighter, etc. in the glove box, console or inside the vehicle. Doing so may cause an explosion during midsummer or the air inside the vehicle is heated.

## Console



- The front seat console can conveniently store things for passengers in the front seats.



### Caution

- Do not store any valuable article on the console for preventing theft.
- Do not store an article that can be damaged easily or creates noise on the console as it may move while driving.
- Do not store any flammable materials or a cigarette lighter, etc. in the console, the glove box, or indoor. Doing so may cause an explosion during midsummer or when the air inside the vehicle is heated.

## Door map pocket

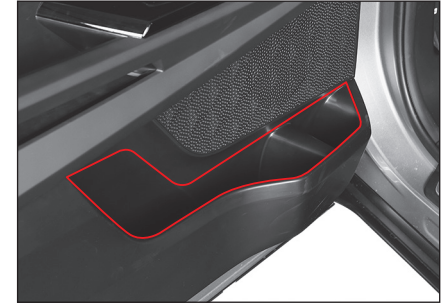

The pocket (bottle tray) where books, magazines, water bottles or beverages can be stored is provided.

## Seat backrest pocket



It can be used conveniently for storing magazines or newspapers.



### Caution

- Do not store scissors, knives, or other objects with an improper size in the seat backrest pocket. Doing so may cause personal injury in the event of sudden braking or a vehicle collision.

## Wireless Phone Charger System\*

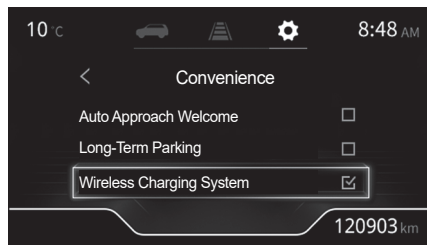

The wireless phone charger system is a device that wirelessly charges the electronic devices (such as mobile phone) that conforms to Qi standard, which is located in front of the transmission selector lever.

The wireless phone charging is available only when the driver sets (ticks) the wireless charging system under User Settings menu in the instrument cluster.

## To Charge Phone

- 1 Close all the vehicle doors and start the vehicle.
- 2 Set (Tick) the wireless charging system under User Settings (User setting → Convenience → Wireless charging system) menu in the instrument cluster.
- 3 Remove everything including the smart key on the wireless charging pad. If there is anything other than the phone on the charging pad, it may not charge.
- 4 Place the wireless charging enabled phone in the center of the charging pad.
- 5 When charging begins, the mobile phone's charging status is indicated by the color of the wireless charging symbol displayed on the lower right side of the 8-inch buttonless integrated control panel:
  - Gray: Wireless charging off
  - Green: Phone charging completed
  - Yellow (solid): Charging in progress
  - Yellow (blink): Charging fault



### Caution

- If any phone is on the wireless charging pad after the ignition is off while the wireless phone charger is operating, a reminder message “The phone is on the wireless phone charger.” is displayed on the instrument cluster. After turning off the ignition, be sure to leave the vehicle with your phone.
- The reminder function is turned on when the ignition switch is changed from the ON position to the ACC or OFF position. However, it does not work when changing the ignition switch from the OFF position to ACC position.

### Notice

- The wireless phone charger system can be used to charge the mobile phones only that conform to the Qi standard. Whether your phone meets the Qi standard can be checked with a separate accessory cover or phone manufacturer.
- The charging function can be turned on (tick) or off (untick) under the User Settings menu in the instrument cluster.

### Caution

- If the temperature or voltage inside the wireless phone charger system exceeds a certain value, the charging function is temporarily stopped to protect the phone and the system.
- The farther your phone is from the center of the charging pad, the less charging efficiency the phone may have.
- Be sure to position your phone in the center of the wireless charging pad.
- Depending on the type of mobile phone cover, charging may not work or a lot of heat may be generated. (e.g., LED cover, thick cover)
- Charging may stop if the mobile phone is not securely pressed against the wireless charging pad.
- If there are magnetic products (credit card, check card, bankbook, ticket and etc.) around the wireless phone charger, its information may be damaged.
- If a metal object is on the wireless charging pad, charging does not work or may stop and a metal object may become hot during charging.
- The mobile phone which is not Qi standard certified may not be charged.



### Caution

- Charging stops temporarily when the smart key detection function is activated. (e.g., when starting the vehicle, immediately after the door is open / closed)
- If the terminal that complies with the Qi standard does not provide a full charge information, charging may continue to generate heat.
- If more than one terminal is placed, charging does not work.
- On some manufacturers' phones, the relevant information may not appear on the instrument cluster.
- For the mobile phones that do not have a built-in wireless charging feature, you have to equip with separate accessories individually.
- If you place a phone or metallic object that does not have wireless charging on the charging pad, you may hear some noise. (The noise is a normal operation sound generated in the process of determining whether the mobile phone can be charged wirelessly, which does not affect the mobile phone and the vehicle.)

## Additional equipment in the luggage compartment\*

### Luggage upper cover

The luggage upper cover is used for covering luggage so that it cannot be seen.

### Installing the luggage upper cover

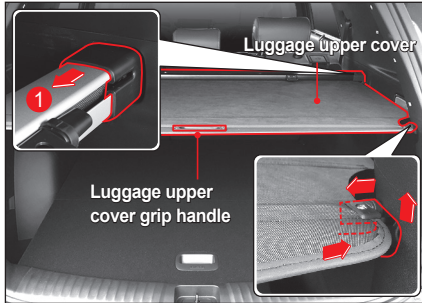

- 1 Fit both ends of the luggage upper cover into the groove on the vehicle body by pressing them in the arrow direction (1).
- 2 Pull the luggage upper cover grip handle and fit it into the groove on the vehicle body.

### Caution

- Do not place any article on top of the luggage upper cover. Doing so may cause the article to bounce forward, injuring an occupant or damaging the luggage upper cover.
- Do not press the top of the luggage upper cover forcibly. Doing so may damage the luggage upper cover.
- Do not relocate the luggage upper cover when it is pulled out. Doing so may damage the luggage upper cover.

### How to store luggage upper cover

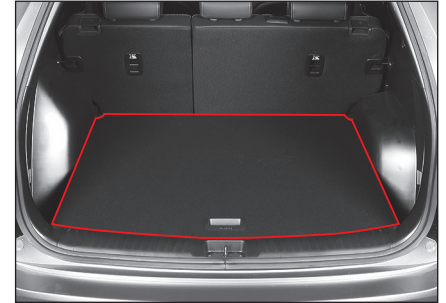

- 1 Lift out the luggage compartment board in the direction of the arrow.

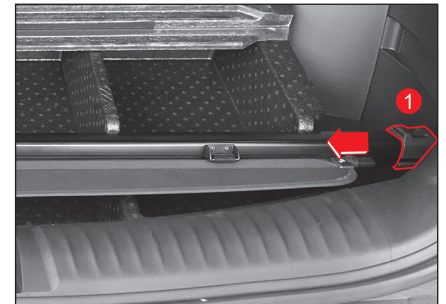

- 2 Pull the left / right end (1) of the luggage compartment upper cover inward and fix it in the groove. The other side is also performed in the same way.



- 3 Make sure that the luggage upper cover is secured firmly.

## Luggage compartment

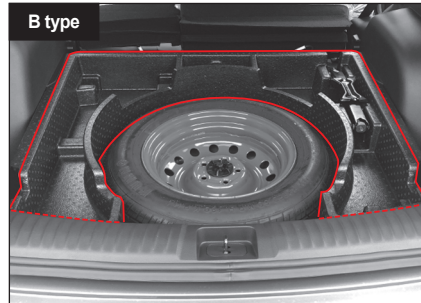
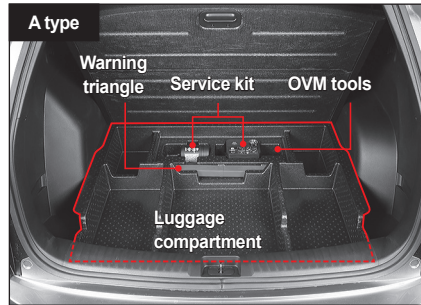

Below the luggage compartment board is a luggage compartment storage box for storing a warning triangle and OVM tools, including a service kit.

## Roof rack\*

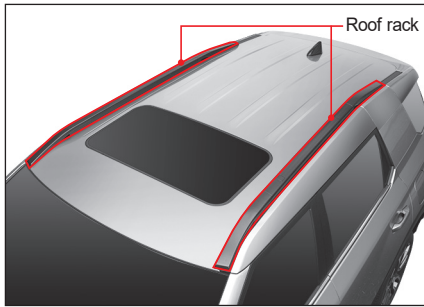

The luggage can be loaded onto the top of the vehicle roof using the roof rack.

Also, leisure sporting goods such as a bicycle, snowboard and skis by installing a separate carrier on the roof rack.

- The maximum loading capacity of the roof rack is 100 kg (220 lbs).

### Warning

- The luggage loaded onto the roof rack should not exceed the maximum loading capacity. The luggage loaded onto the roof rack should not stick out of the roof. If the maximum loading capacity is exceeded or the luggage sticks out of the roof rack, the relevant vehicle or other vehicles may be damaged. In addition, it adversely affects the driving stability of the vehicle and may cause an accident while driving.
- Fix the luggage to the roof rack safely, and in case of driving for a long period of time, check the fixing status of the luggage frequently. If the luggage loaded onto the roof rack falls off from the vehicle, other vehicles may be damaged or a pedestrian may get injured. Also, it may cause a bigger accident.
- When luggage is loaded onto the roof rack, the center of gravity of the vehicle becomes higher. If you control the steering wheel suddenly while applying sudden braking, making sharp turn or driving at a high speed, the vehicle may become unstable, causing an accident or overturning of the vehicle.
- If the luggage is loaded onto the roof rack, check the tightening status of roof rack fixing bolts and nuts frequently.
- Drive the vehicle at a low speed if possible when luggage is loaded onto the roof rack.

### Caution

- Caution should be taken that if you load luggage onto the roof rack of a vehicle where a sunroof is installed, the luggage should not interrupt the operation of the sunroof.

### Notice

- A protective gear such as a cushion or a cloth can be inserted between the luggage and the roof rack in order to prevent the vehicle from being damaged by contact between the luggage loaded onto the roof rack and the vehicle roof.

